

Fire Protection Technical Guideline

Identifier: TvMI 13.3:2022.06.13.

Subject:

Explosion protection (unofficial English translation)

The goal of this *unofficial and non-binding English translation* of the Hungarian Fire Protection Technical Guideline (TvMI 13.3:2022.06.13) is to help designers, service providers and inspectors without proper Hungarian knowledge to understand the technical background of the specific Hungarian rules and regulations, like the National Fire Protection Regulation 54/2014. (XII. 5.) of the Ministry of the Interior or the Fire-Protection Act No. 1996/XXXI. and hence provide the same content to non-domestic investors and their employees.

This English text has been published as a private translation, with the funding of the **ExNB Certification Institute** (Notified Body for ATEX and Fire-Protection). Although we have strived for it, we know that translating a complex technical and legal text (especially when it is the first edition) can never be flawless. Therefore, on the one hand, we would like to draw your attention to the fact that in case of any deviation from the original text, the original Hungarian text shall prevail. If anyone anywhere finds any discrepancies or inaccuracies, we appreciate your reporting it to us.

The text of the original Hungarian publication can be downloaded here:

<https://www.katasztrofavedelem.hu/34077/robbanas-elleni-vedelem>

This English edition may be reproduced freely in its unaltered content and form and may only be distributed free of charge (57 pages in total).

Budapest, May 27, 2022



Arpad Veress
Managing Director
ExNB Certification Institute

This Fire Protection Technical Guideline is valid from June 13, 2022 and at the same time the Fire Protection Technical Guideline with the identifier TvMI 13.2: 2021.01.15 is repealed.

The Fire Protection Technical Guideline (hereinafter: TvMI) with a special focus on explosion protection was developed by the Technical Committee on Fire Protection as provisioned by §3/A(2) of Act XXXI of 1996 on Fire Protection, Technical Rescue And Fire Brigades (hereinafter: Ttv.) This TvMI should be used on a voluntary basis. The application of the TvMI should be considered as a means to comply with the relevant requirements and the safety criteria of the National Fire Protection Regulations (hereinafter: OTSZ). The TvMI and its amendments may be viewed at and downloaded free of charge from the website of the National Directorate General for Disaster Management (www.katasztrofavedelem.hu). The TvMI may be distributed and copied as long as its content and format are kept unaltered.

Always use the TvMI in force.

Content

1. Introduction	3
2. Terms and definitions	3
3. Explosion protection	4
4. Methodology of explosion protection	4
5. Process of explosion protection.....	5
6. Installation criteria in potentially explosive atmospheres	13
7. Additional installation criteria for specific cases	17
8. Sizing the surface of relief vents	22
9. Criteria for positioning gas detectors	32
Legislation and standards referred in the Guideline	35
Annex A	
Methodology and practical application of zone classification calculations	38
Annex B.	
Determination of the level of explosion hazard	44
Annex C.	
Explosive dusts.....	46

¹modified 15.01.2021.

²modified 13.06.2022

1. Introduction

- 1.1. The purpose of this Fire Protection Technical Guideline (TvMI) is to describe technical solutions that meet the legal requirements of explosion protection.
- 1.2. According to §3/A(3) of the Ttv., the level of security specified in the OTSZ may be achieved by:
 - a) compliance with national fire safety standards
 - b) using methods and technical solutions described in the TvMIs, or
 - c) using solutions partially or completely different from those described in the TvMI or the national standard, but providing for the same level of safety as verified by their designer.

The “Notes”, “Annexes” and “Examples” in the TvMI provide guidelines and explanations for the main text. Deviations from these, however, do not equal to the violation of the TvMI in the sense of §3/A(3) c) of the Ttv.

¹Note:

According to OTSZ explosive substances are essentially regulated by Regulation (EC) No 1272/2008 of the European Parliament and of the Council of 16 December 2008 on classification, labelling and packaging of substances and mixtures, amending and repealing Directives 67/548/EEC and 1999/45/EC, and amending Regulation (EC) No 1907/2006.

- 1.3. ²When choosing the solutions included in the TvMI, the solutions included in the version valid at the time of construction planning (based on the valid building permit) or, in the case of construction activities, those valid at the time of the building permit procedure and meeting the given requirements shall be considered. Should the TvMI solutions have been extended or altered after the start of the building permit procedure, they should be nevertheless applicable presuming
 - 1.3.1. the legislation related to fire safety with special regard to building permit procedure has not changed; however, the solutions of the revised TvMI that meet the relevant requirement are fully applied, or
 - 1.3.2. the legislation related to fire safety with special regard to building permit procedure has changed and both the legislative requirements and the solutions of the related TvMI that meet the relevant requirements are fully applied.

²Note 1. In procedures pending when the amendments of OTSZ enter into force, the provisions of the TVMI in force after the entry into force of the amended OTSZ shall prevail, should the builder or investor decide to fully apply the provisions of the amended OTSZ.

Note 2. When the building permit procedure has been amended, the provisions of the OTSZ related to the original planning application have changed, and the provisions in force have been taken into account when amending the planning application, the provisions of the TvMI in force after the entry into force of the amended OTSZ shall prevail, regarding the amendments of the procedure.

- 1.4. ²In the case of conversions, extensions, renovations, modernisation, change of use or change of fire safety situation without a building permit procedure, the TvMI solutions that meet the requirements of the OTSZ in force at the time of commencement of the relevant (construction) activity shall apply.

²Note 1. The solutions contained in the TVMI in effect should be applied at least in the scope and extent of the change.

¹modified 15.01.2021.

²modified 13.06.2022

²Note 2. In such cases, the effects of changes on the fire safety of the building or part of a building should always be considered. When converting or renovating buildings, efforts should be made to use solutions which improve the fire safety situation of the building while the impairment of the existing situation shall not be allowed.

²Note 3. It may also be necessary to revise or update the plans prepared prior to the commencement of (construction) activities according to Section 1.4 if they do not meet the requirements of the OTSZ in force at the time of commencement of the (construction) activities.

- 1.5. For the purposes of this TvMI, the Hungarian term “**robbanás elleni védelem**” and “**robbanásvédelem**” are considered the same, translated into English as “explosion protection”.

2. Terms and definition

- 2.1. For this TvMI, the terms and definitions of the OTSZ and the relevant standards shall apply.
- 2.2. A 2.1. For the purposes of this Directive, the following definitions shall apply:
- 2.2.1. *Detonation*: The propagation speed of the flame front exceeds 340 m/s
- 2.2.2. *Detonation arrestor*: a device built into pipelines to prevent the propagation of the explosion; it is installed at locations where the propagation speed of the flame front exceeds 340 m/s.
- 2.2.3. *Factory sealed packaging*: sealed container with the factory sealing intact.
- 2.2.4. *²Bursting and bursting-opening vents*: building structures destroyed by or open as a result of harmful explosion overpressure in the boundary structures of buildings or parts of buildings, thus allowing pressure to escape.
- 2.2.5. *²Bursting vents*: building structures facilitating the opening of interior spaces for the purpose of overpressure relief, by means of being destroyed.
- 2.2.6. *²Bursting-opening vents*: building structures with adjustable opening pressure facilitating the opening of interior spaces for the purpose of overpressure relief by means of opening, rotating or flapping.
- 2.2.7. *Flame arrestor*: a device built into pipelines to prevent the propagation of the explosion; it is installed at locations where the propagation speed of the flame front stays below 340 m/s even in the worst case scenario.
- 2.2.8. *²Relief*: venting of explosion overpressure to a space where it is allowed to expand and thus relieving the interior space relieved of its harmful effects.
- 2.2.9. *²Relief reception space*: an enclosed space receiving the overpressure from rooms not connected to an open area and transferring such overpressure to an open area.
- 2.2.10. *²Secondary explosion*: an explosion ignited by another explosion already in progress.
- 2.2.11. *²Opening pressure*: pressure initiating the opening of a bursting-opening vent
- 2.2.12. *Normal operation*: the operating status of a plant or technology operating within its design parameters.

¹modified 15.01.2021.

²modified 13.06.2022

- 2.2.13. ²*Reduced overpressure*: pressure that builds up in the interior space for a short time despite effective pressure relief.
- 2.2.14. ¹*Potentially explosive technology*: all technological systems where an explosive medium may be formed during operation, including potentially explosive technologies according to §4x) of the Ttv.
- 2.2.15. *Explosion protection chapter*: part of the technical documentation describing explosion protection solutions.
- 2.2.16. *Storage manipulation*: opening the unopened and sealed factory packaging and container of the stored substance or the packaging and container qualified for transport to dose and unload the stored material.
- 2.2.17. ²*Bursting-opening vent with a safe direction of relief*: a bursting-opening vent with its extreme position when opened defined in a way so that the relief is deflected in a safe direction.
- 2.2.18. ²*Progressive collapse*: The primary supporting structure of a building fails, resulting in the failure of an adjoining primary structure or structures.
- 2.2.19. *Zoning*: classification of areas where explosive atmospheres may develop into zones with potentially explosive atmospheres.
- 2.2.20. *Zoning documentation*: documentation including the justification of the zoning of a given area (calculations, CFD models, legal references, etc.).

3. Explosion protection

- 3.1. The aim of explosion protection is to protect the area by means of technical and organizational solutions, implemented through directives, legislation, standards and technical regulatory documents aiming at preventing explosions and/or diminishing the adverse impacts of potential explosions, which provide for safe operation and work in the presence of hazardous technologies with a relevance to explosion protection (as defined in the Ttv. and Act CXXVIII of 2011 concerning disaster management)
- 3.2. Regarding design, installation and operation, explosion protection is based on the following methods:
- 3.2.1. In the framework of primary explosion protection, the desired result shall be obtained by replacing or eliminating the potentially explosive substance(s) or by limiting the amount of the combustible substances.
- 3.2.2. In the framework of secondary explosion protection, the relevant potential ignition sources shall be excluded from areas with potentially explosive atmospheres where an explosive atmosphere is formed.
- 3.2.2.1. Possible ignition sources:
- Hot surfaces
 - Mechanical sparks
 - Flame, hot gases
 - Electric sparks
 - Stray electric current and cathodic protection
 - Electrostatic charge
 - Lightning protection
 - Electromagnetic waves

¹modified 15.01.2021.

²modified 13.06.2022

- i) Ionizing radiation
 - j) High frequency radiation
 - k) Ultrasound
 - l) Adiabatic compression
 - m) Chemical reactions, autoignition
- 3.2.3. In the framework of tertiary explosion protection, the effects of the expected explosion shall be controlled and mitigated when necessary.

4. Methodology of explosion protection

- 4.1. To avoid explosions, the following methodology should be followed when applying explosion protection. The purpose of the methodology is to assess the relevant explosion protection risks and implement appropriate measures to achieve the desired level of safety.
- 4.1.1. The substances with explosive properties should be identified among those processed, stored, transported or produced.
- Note:*
For this process, MSZ EN 60079-20-1 and MSZ EN ISO / IEC 80079-20-1 and the safety data sheets of hazardous substances describing combustion and ignition properties as well as explosive properties may be considered.
- 4.1.2. In the space surrounding potentially explosive substances, zones with potentially explosive atmospheres are formed. The boundaries of these shall be established in the framework of the zoning process.
- 4.1.3. The area of zones shall be controlled by technical and organizational means to the extent required by the technology.
- 4.1.4. Zoning shall be carried out in accordance with the relevant standards and regulations. The results of the zoning process shall be recorded in the zoning documentation.
- 4.1.5. In the established zones, only explosion-proof electrical and non-electrical products that have been designed, installed, commissioned and operated in accordance with the criteria applying to the given zone may be used.
- ¹
- 4.1.6. ¹Furthermore, work processes in zones with potentially explosive atmospheres shall be designed in such a way that do not constitute additional sources of ignition.
- 4.1.7. ^{1,2}If the technological processes within a given technology may result in the creation of ignition sources potentially leading to explosion, technical solutions suitable for mitigating the impacts of potential explosions shall be applied. Explosion proof design shall be verified by relevant calculations. **Furthermore, technical solutions shall be applied to prevent the spread of potential explosions.**
- Note:*
Examples include flame arresters, explosion arresters, bursting panels, vents, deflectors, non-return valves, pinch valves, Q-boxes etc.
- 4.1.8. The operability of explosion-proof products used within the established zones with potentially explosive atmospheres and the technical solutions installed in other areas for the purpose of explosion protection as well as their conformity to explosion safety criteria shall be maintained as long as the potentially explosive technology is applied.

¹

5. Explosion protection process

¹modified 15.01.2021.

²modified 13.06.2022

5.1. Planning

5.1.1. ¹To meet the requirements of §99(1) of the OTSZ, the **explosion risk level shall be determined and, as necessitated by this level**, a file compiled that verifies the safe operation of the planned technology in the planned environment.

5.1.1.1. ¹Risk levels:

- a) negligible risk,
- b) potential risk

5.1.1.2. ¹Explosion risk levels may be established according to Annex B or on a case by case basis by the designers of individual technologies.

5.1.1.3. ¹If the explosion risk is negligible, it will not be necessary to draw up an explosion protection plan.

5.1.1.4. ¹Where there is a potential explosion risk, the design documentation shall include an explosion protection chapter in accordance with the requirements of 5.1.3.

¹Note:

The explosion protection chapter ensures that the explosion protection requirements are met and provides for a comprehensive explosion protection concept for the entire facility or technological system. The explosion protection chapter also has an impact on the related plans, where explosion protection solutions shall be considered during the design process.

5.1.2. The experts involved in compiling the explosion protection chapter shall describe how the explosion protection regulations are met and legal regulations considered as well as any deviations.

5.1.3. According to the methodology described in Chapter 4, the explosion protection chapter shall include at least the following (detailed to the necessary extent):

- a) a brief description of the planned technology, specification of the extent of design,
- b) description of the explosion risk,
- c) description of the properties of substances with explosion protection relevance,

¹Note:

The parameters of hazardous gases/vapours/mists with explosion protection relevance are given in MSZ EN ISO/IEC 80079-20-1 and MSZ EN 60079-20-1. The standard only provides a few parameters for several substances, or none at all, so other authentic sources (e.g. test reports) may also be used (in the case of dusts, the test methodology is provided by MSZ EN ISO/IEC 80079-20-2). In the absence of reliable sources, the design shall consider the most hazardous gas/dust group.

- d) zoning documents of the planned technology,
- e) description of the level of protection for the electrical and non-electrical equipment to be installed,
- f) analysis of technological risks to justify the level of safety (from an operational aspect),

¹Note:

Ignition source analysis according to MSZ EN 1127-1 standard or internationally accepted standardised method of hazard analysis (E.g. HAZOP, HIBAF, FMECA, etc.).

g) protection systems of the designed technology with explosion protection relevance, including at least the following aspects:

- g.a) structural protection: explosion-proof design, resistance to reduced pressure, bursting or bursting-opening vent (bursting panels, bursting discs, explosion doors), Q pipes, flame arresters, detonation arresters, liquid seals,

¹modified 15.01.2021.

²modified 13.06.2022

protection devices with bursting or opening elements, other constructional solutions, etc.,

- g.b) instrumental protection with associated interlocks,
- g.c) built-in explosion protection systems: explosion suppression, fire dampers, IS barriers, quick-closing fittings and dampers, pinch valves, flow restrictors, rotary air lock valve, double locking fittings, chokes, vent ducts, inerting, extinguishers etc.
- gd) verification of the appropriate level of safety in accordance with the relevant technical specifications,

Note:

Based on MSZ EN 1127-1.

- g.e) design of escape routes, emergency exits,

Note:

Also considering the provisions of the TvMI "Kiürítés" (Evacuation).

- g.f) ¹assessing the need for an emergency power supply for the protection systems, determining the necessary duration of maintaining functionality,
- g.g) protection against electrostatic discharge,

Note:

Also considering the provisions of the TvMI "Villamos berendezések, villámvédelem és elektrosztatikus feltöltődés elleni védelem" (Electrical equipment, lightning protection and protection against electrostatic discharge)

- g.h) lightning and surge protection,

Note:

Also considering the provisions of the TvMI "Villamos berendezések, villámvédelem és elektrosztatikus feltöltődés elleni védelem" (Electrical equipment, lightning protection and protection against electrostatic discharge).

- g.i) maintainability,
- g.j) markings (zone boundaries, grounding points, prohibition of bringing ignition sources to the area) to be indicated by the designer.

Note:

The explosion protection chapter shall be reviewed as necessary when planning the construction and during construction and operation.

5.1.4. Contents of the zoning documentation

- 5.1.4.1. The purpose of the zoning documentation is to document the classification of areas with potentially explosive atmospheres into zones with potentially explosive atmospheres.
- 5.1.4.2. The zoning documentation shall include (detailed to the necessary extent)
 - a) the extent of design including the exact boundaries,
 - b) a brief description of the planned technology,
 - c) description of the explosion risks,
 - d) description of properties of substances with relevance to explosion protection.
- 5.1.4.3. Areas with potentially explosive atmospheres shall be classified into zones with potentially explosive atmospheres as provisioned by the relevant legislation and technical requirements (e.g. standards) or standard industry practice. The classification shall be made in a written form with multi-perspective drawings demonstrating the extent of zones when it is necessary for a proper understanding of the information presented.

¹modified 15.01.2021.

²modified 13.06.2022

- 5.1.4.4. ¹The classification of areas with potentially explosive atmospheres into zones with potentially explosive atmospheres shall be supported by calculations and a detailed technical justification (if possible).

Note:

The calculations shall be presented in such a way that the methods, findings and conclusions of subsequent reviews can be understood and reconstructed by practitioners.

- 5.1.4.5. ¹To meet the requirements of §99(1) of the OTSZ, an updated zoning document shall be prepared for the processes affecting technologies, as listed below,:
- during the entire planning process,
 - commissioning,
 - in the case of **transforming or** modifying the technology, if the activity may affect the extent of the area with potentially explosive atmospheres or the method of protection.

5.2. Construction

- 5.2.1. To meet the requirements of §99(1) of the OTSZ, the following criteria shall apply when installing explosive technologies:

Note:

See also the construction regulations concerning fire safety (OTSZ regulations and Chapter 7 of this TvMI).

- 5.2.1.1. Explosion-proof equipment shall be installed in a documented manner, in accordance with the relevant plans.
- 5.2.1.2. Explosion-proof equipment and protection systems shall be installed by authorized persons as prescribed by the relevant legislation.
- 5.2.1.3. When finishing the construction phase, the contractor shall provide the investor/operator with at least the following documents (as applies) as part of the as-built documents:
- as-built designs (architectural, electrical, mechanical, explosion protection, fire protection etc.)
 - declaration by the technical manager in charge,
 - declaration by the contractor,
 - documents verifying compliance with personal qualification criteria
 - ¹EU Declarations of Conformity by the manufacturer as required by the Regulation 35/2016. (IX.27) NGM,
 - ¹ATEX certificates according to the Decree 35/2016. (IX.27) NGM,
 - Fire Safety Compliance Certificate,
 - manual in Hungarian,
 - manufacturer's documents for electrical distributors and itemized test reports
 - ¹certificate of the initial inspection of electrical equipment, according to the Decree 40/2017. (XII.4.) NGM including:
 - the report on the electric safety review,
 - the report on the cable insulation resistance measurements,
 - the test report on reviewing the overload protection settings of electric motors

¹modified 15.01.2021.

²modified 13.06.2022

k) ²report on the pre-commissioning compliance reviews of explosion-proof electrical equipment (reviews shall cover all pieces of equipment installed in non-explosive atmospheres, but connected to explosion-proof equipment, e.g. isolators, ATEX certified PTC thermistor cards),
other technology-specific test reports (e.g. interlocks).

k.a) ²Where intrinsically safe electric circuits are installed, the Report specified under point k) shall be supplemented with the RLC test report

l) report on reviewing electrostatic charge and discharge protection compliance,

m) lightning protection standardization review report (partial and first)

n) ²other technology-specific test reports (e.g. report on latch test, IQ/OQ/PQ)

Note:

From the above, only those with relevance to the specific installation need to be submitted.

5.2.1.4. Before the explosive technology is commissioned, at least the following documents shall be prepared:

- a) explosion protection document (explosion prevention plan for mines),
- b) explosion protection document (explosion prevention plan for mines) – document confirming the related training,
- c) instructions for the operation, handling and maintenance of explosion-proof equipment,
- d) registration of explosion-proof equipment (inspection file according to MSZ-EN 60079-14),
- e) cleaning plan (for technologies with dust explosion risk).

5.3. Commissioning

5.3.1. ¹To meet the requirements of §99(1) of the OTSZ, commissioning after construction shall comply with the criteria detailed in 5.3.2. - 5.3.3.

5.3.2. ¹A fire safety test according to the relevant legislation shall be performed.

Note:

§20(2) of Act XXXI of 1996 prescribes a fire safety test for the launching of flammable or explosive technologies.

5.3.2.1. The **test** documentation shall include at least the following:

- a) place and time of the test,
- b) subject of the test,
- c) brief description of the technology,
- d) hazardous substances,
- e) legislation and standards considered,
- f) zoning,
- g) built-in explosion protection and fire protection systems,
- h) ignition source analysis for the whole technology,
- i) operating conditions (technical and personal conditions),

¹modified 15.01.2021.

²modified 13.06.2022

- j) ¹verification of the adequate value of limiting oxygen concentration in the case of applying inert or protective gases,
 - k) qualification of the technology (operation recommended or not).
- 5.3.2.2. A report shall also be made on the on-site visual inspection required for this test.
- 5.3.2.3. The test shall be repeated as necessary if the explosive technology has been extended or modified.
- 5.3.2.4. The person performing the test shall consider the contents of the explosion protection chapter.
- 5.3.3. ¹Compliance with the explosion protection requirements shall be reviewed during commissioning.

Note:

According to §4(8) of the Decree 3/2003. (III.11.) FM-SZCSM

- 5.3.4. ¹Preparing an explosion protection document (in the case of mines, an explosion prevention plan) is pre-requisite for operation according to the relevant legislation.

Note:

The preparation of these documents is regulated by the Joint Decree 3/2003 (III. 11.) FMM-EszCsM on the minimum occupational safety requirements for workplaces in potentially explosive atmospheres; for mines, it is the Decree 4/2001(II. 23.) GM on the minimum level of safety and health protection requirements to be implemented in mining plants.

5.4. Operation

- 5.4.1. ¹To meet with the requirements of §99(1) of the OTSZ, the establishment of explosion protection systems and maintaining the functionality thereof shall comply with the following criteria:

5.4.1.1. ¹The established explosion protection system shall provide for explosion protection as long as the technology is in operation,

5.4.1.2. ¹The following documents shall be available during operation:

- a) explosion protection documents (in the case of mines, explosion prevention plan),

Note:

The preparation of these documents is regulated by the Joint Decree 3/2003 (III. 11.) FMM-EszCsM on the minimum occupational safety requirements for workplaces in potentially explosive atmospheres; for mines, it is the Decree 4/2001(II. 23.) GM on the minimum level of safety and health protection requirements to be implemented in mining plants.

- b) valid (up-to-date) zoning documents,
- c) instructions for the operation, handling, maintenance and repair of explosion-proof equipment,
- d) registration of explosion-proof equipment (inspection file according to MSZ-EN 60079-17),
- e) cleaning plan (for technologies with dust explosion risk).

5.4.1.3. ¹If the technology is modified and the change affects the extent of the explosive atmosphere or the method of protection, the zoning documentation shall be updated and explosion protection re-designed accordingly,

¹modified 15.01.2021.

²modified 13.06.2022

- 5.4.1.4. 1) the required reviews are duly performed (the review shall include the assessment of the environment of the electrical equipment according to §277(5) of the OTSZ and the classification of areas into zones with potentially explosive atmospheres)
- 5.4.1.5. 1) the non-compliances found are corrected,
- 5.4.1.6. 1) the compliance of bursting and bursting-opening relief vents, the ventilation technology, and gas detectors is continuously provided for,

Note:

The technical condition of the equipment used in potentially explosive atmospheres shall comply with the criteria set forth by the manufacturer's documents throughout their service life and application. Compliance with the criteria set forth in the instructions for use shall be documented.

- 5.4.1.7. 1,2) The equipment used and the protective clothing shall comply with the valid zone classification.

1) Note 1:

The data plates of the equipment installed in zones with potentially explosive atmospheres shall be readily identifiable and legible.

Manufacturer's logo, pls web address	Type		
	Ex II 2 G	Ex db eb IIC T4 Gb	-35°C <T _a < 55°C
	CE xxxx	xxx 17 ATEX 9999 X	
	Additional technical parameters, e.g. IP protection		

Figure 1: Data plate (example)

1) Note 2:

Protective clothing shall be suitable for use in potentially explosive atmospheres. This requirement shall apply to all elements of the personal protective equipment used in potentially explosive atmospheres, such as safety helmets, goggles, underwear and outerwear, safety shoes, protective gloves, etc.

Note 3:

2) In accordance with the PPE Guideline, protective clothing shall be supplied with a manufacturer's certificate of conformity regarding the particular potentially area with explosive atmosphere. The certificate shall also include other conditions e.g. the instructions for washing (validated washing procedure, number of washes etc.) - source: manufacturer's documentation. Users shall be able to demonstrate compliance with the criteria of the certificate. The provisions of the PPE Guideline shall be fully complied with, e.g. short-sleeved clothing may not be worn in potentially explosive atmospheres.

- 5.4.2. 1) To meet the requirements of §177(8) of the OTSZ, the following criteria shall apply:
 - 1a) zones shall be marked according to the zoning document with the marks clearly visible and legible,

1) Note:

For example: Zone IIIB T4 or Zone IIIB T4

- 1b) up-to-date records of electrical and non-electrical equipment operated in areas with potentially explosive atmospheres shall be maintained,

1) Note 1:

Individual pieces of explosion-proof equipment shall be clearly identifiable, e.g. by serial number, QR code, barcode, RFID (Rb design). Such an identification system also serves as a basis for life cycle tracking. The replacement of identifiers (when necessary) shall be properly documented (life cycle tracking).

1) Note 2:

Electrical products may be registered for example according to MSZ EN 60079-17. A similar registry system is recommended for non-electrical products, too.

1) Note 3:

¹modified 15.01.2021.

²modified 13.06.2022

According to §99(6) of the OTSZ, "In explosive atmospheres, only electrical and non-electrical products equipped with an explosion proof mode of protection corresponding to the given zone with potentially explosive atmosphere may be used." For products (electrical, non-electrical) installed before the ATEX directive entered into force and thus not necessarily complying with it, the operator may apply a fit-for-purpose assessment (FFPA) procedure; see MSZ EN 60079-17 Annex 'C' (applicable to both electrical and non-electrical products).



Figure 2: Data plate on a motor with explosion proof design installed before the ATEX directive entered into force

c) ¹when determining the conditions for occasional flammable activity, the explosion prevention conditions specified in the explosion protection document shall be recorded and checked (e.g. personal competence, gas detector, etc.),

d) ¹explosion-proof products shall be operated in accordance with the relevant technical requirements and periodically reviewed against the explosion protection criteria.

¹Note:

The correction of non-compliances and the adequacy of corrective actions shall be verified by a detailed review with the results recorded in a report.

e) ¹the necessary maintenance, repair and restoration activities shall be carried out to provide for further use and operation.

¹Note 1:

Repairs and restorations may only be carried out by workshops and/or manufacturers specialising, as set forth by MSZ EN 60079-19, in repairing explosion-proof equipment. Repaired or restored machines, tools and equipment shall be marked in accordance with the standard and the activities properly documented (life cycle tracking). Repaired or restored pieces of equipment may only be re-commissioned after a detailed inspection.

¹Note 2:

Marking according to the requirements of the standard – when the item has been repaired according to the manufacturer's instructions (Figure 3).

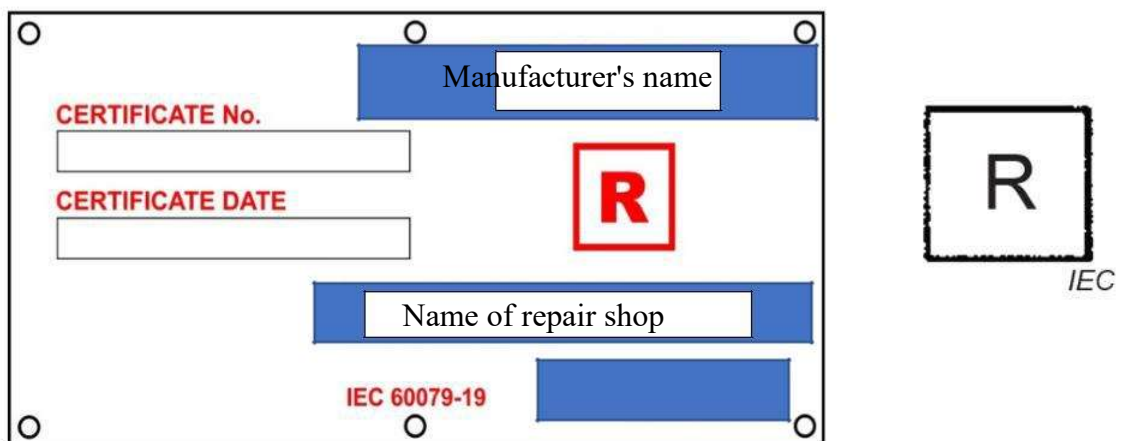

Figure 3

¹modified 15.01.2021.

²modified 13.06.2022

*1*Note 3:

Marking according to the requirements of the standard regulating the applied mode of protection (Figure 4).

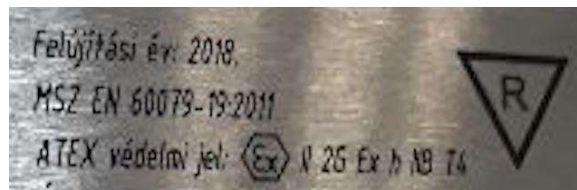

Figure 4

6. Installation criteria in potentially explosive atmospheres

- 6.1. ¹To meet the explosion protection provisions of §99 of the OTSZ, the design of the facility shall comply with the criteria of the sections 6.2 to 6.6, the contents of Chapters 7 and 8 and relevant standards and legislation.
- 6.2. Products used in potentially explosive atmospheres shall have an explosion-proof design.

6.3. General installation criteria

- 6.3.1. ¹In the presence of flammable gases/vapours/mists, where the combined volume of the established zones with potentially explosive atmospheres formed around explosive technology reaches 20% of the total volume of the room, or the combined floor area of zones exceeds 20% of that of the room, the room is classified as explosive in terms of fire safety risks and shall be designed as provisioned by the sections 6.3.2 and 6.3.3.

*1*Note:

If a room is classified as explosive, it will not automatically result in the compulsory use of explosion-proof products in the entire volume of the room (also outside the explosive zones); see 6.3.6.

- 6.3.2. The room or the interconnected rooms shall be separated from non-explosive rooms by fire partitions matching the risk classification of the building.
- 6.3.3. Within a group of rooms consisting of explosive rooms, individual rooms may be separated by fire partitions matching the risk classification of the building or building section.
- 6.3.4. Other rooms, not classified as explosive, but nevertheless containing explosive technology shall be separated from neighbouring rooms by fire partitions matching the risk classification of the building or building section.
- 6.3.5. ¹In rooms containing explosive technology (in the proximity of the technology as required) and in explosive rooms or groups of rooms, only such construction products, construction methods, electrical and non-electrical devices and equipment are allowed which do not constitute an ignition source for explosive atmospheres, either by themselves or due to their use.

*1*Note 1:

Where the use of such products etc. is unavoidable, the mode of protection described in later sections shall be used to prevent the formation and spreading of explosive atmospheres.

*1*Note 2:

Regarding lightning protection, the TvMI "Villamos berendezések, villámvédelem és elektrosztatikus feltöltődés elleni védelem" (Electrical equipment, lightning protection and protection against electrostatic discharge) provides additional solutions for facilities classified as explosive or having a limited risk of explosion.

¹modified 15.01.2021.

²modified 13.06.2022

- 6.3.6. In the presence of flammable gases/vapours/mists, where the volume or combined volume of the established zones with potentially explosive atmospheres formed around explosive technology reaches 4% of the total volume of the room:
- the entire volume of the room shall be classified as explosive;
 - the volume outside the originally established zones with potentially explosive atmospheres shall be classified as Zone 2 (gases/vapours/mists) or Zone 22 (dusts);
 - in the extended zones thus established, the most dangerous gas group or dust group present and the related strictest temperature class or the lowest limit temperature shall be considered.

Note:

Where zones with potentially explosive atmospheres are established in small rooms, the classification of the entire room regardless of its volume should be considered.

6.4. Other explosion prevention measures

- 6.4.1. When identifying risks related to explosive technologies, other protection measures may be taken during the design process to prevent the spread of the explosive zone.
- 6.4.2. Where the risk analysis of the explosive technology justifies, rooms with and without explosive technologies may be separated under normal operating conditions by a directly ventilated or pressurized (50 Pa) lobby that prevents the spreading of the zones with potentially explosive atmospheres.

Note:

It is recommended to construct fire partitions (fire protection class A1 or A2) to separate this lobby from the other parts of the building.

- 6.4.3. The following actions shall be performed to maintain an acceptable concentration of potentially explosive gases, vapours and mists:
- in rooms with explosive technologies, the rate of ventilation shall facilitate the effective dilution of the explosive atmosphere to a concentration below 20% of the lower explosion limit (LEL) (or some another, pre-determined value below 20%, which is considered safe).

Note 1:

When determining the positions of gas detectors, the person responsible for planning shall consider the classification of the areas into zones, the location of the release sources, the relative density of the combustible gas/vapour, air flow conditions, temperature conditions etc.

Note 2: These factors shall also be considered when the areas with potentially explosive atmospheres are classified into zones.

Note 3:

Where the relevant standard or regulations specify a Lower Flammable Limit (LFL) and these values are more stringent than LEL 20%, these may also be used to provide for effective ventilation.

Note 4:

The definition of Lower Flammable Limit is given by 3.55 of MSZ EN IEC 60079-0 (In Hungarian, „alsó éghetőségi határérték” (ÁÉH) and „alsó gyulladási határ” (AGYH) are identical terms and both refer to the Lower Flammable Limit).

Note 5:

The definition of Upper Flammable Limit is given by 3.90 of MSZ EN IEC 60079-0 (In Hungarian, „felső éghetőségi határérték” (FÉH) and „felső gyulladási határ” (FGYH) are identical terms and both refer to the Upper Flammable Limit).

- The potentially explosive atmosphere may be prevented from becoming explosive by the application of inerting or protective gases i.e. by modifying the limiting oxygen

¹modified 15.01.2021.

²modified 13.06.2022

concentration. (The actual value of the limiting oxygen concentration depends on the substance/mixture. It may be determined by calculation, but the value is always above 4% v/v). The inert or protective gas shall be provided in the amount required by normal operation and emergency response, always considering the requirements of the relevant standards as well. **The value of the limiting oxygen concentration shall be verified by tests.**

¹Note 1:

The value of the limiting oxygen concentration shall be verified by tests focusing on fire safety. The provisions for testing limiting oxygen concentrations are provided by CEN/TR 15281:2006 – Guidance on Inerting for the Prevention of Explosions.

¹Note 2:

When reducing oxygen concentrations and applying inerting, the protection of human life shall always be considered.

6.4.4. In the event of an unexpected and dangerous increase in the concentration of an explosive substance:

a) ¹if the concentration of the explosive atmosphere exceeds 20% of the LEL, workers in the vicinity of the technological equipment and those working in the impacted area shall be warned by a light signal; if necessary, the degree of ventilation for the room or the technology shall be increased,

¹Note:

The degree of ventilation may depend on the hazardous nature of the technology concerned and the quality of the source of release.

b) ¹if the concentration of the explosive atmosphere exceeds 40% of the LEL, **those in the vicinity of the technological equipment and in the relevant control (instrument) room shall be warned by light and sound signals**

- b.a) **if necessary**, the degree of ventilation for the room or the technology shall be increased,
- b.b) the discharge, production or generation of the explosive atmosphere and its supply to the hazardous piece of equipment shall be ceased, even if it necessitates the shutting down of the relevant technological lines,
- b.c) where the technology allows, the entire technological system should be shut down as necessary.

¹Note 1:

Where the relevant standard or regulations specify Lower and Upper Flammable Limits (LFL and UFL) and these values are more stringent than LEL 20% or 40%, these may also be used to provide for effective ventilation. For a given process location, the ventilation efficiency for a given gas/vapour/mist emission is considered sufficient if it is able to reduce the volume (V_z) of the explosive zone to a negligible value ($V_z < 0.1 \text{ m}^3$).

¹Note 2:

²Where zoning was based on the provisions of MSZ EN IEC 60079-10-1 i.e. the process considered the grade of release, the operational safety of ventilation and the degree of ventilation, increasing the air flow volume of the planned and operated fans will not be necessary when hazardous gas concentrations are detected, unless provisioned otherwise by the relevant legislation or standards.

6.4.5. ¹The application of the methods defined in 6.4.3. and 6.4.4. shall be controlled by an automatized system (an explosion proof system where necessary), with the following specifications:

- c) the system is able to perform the interventions at the expected concentration levels,
- d) operational safety is provided for by redundant systems depending on risk levels,
- e) where prescribed by the risk assessment of the explosive technology, an adequate uninterruptible power supply shall be available for normal and/or

¹modified 15.01.2021.

²modified 13.06.2022

emergency operation until the technological system is shut down and the hazard is eliminated.

6.5. Mitigation of explosion impacts. Modes of protection

6.5.1. If, due to the nature of the technology, the explosion risk **cannot be fully eliminated**, the harmful impacts of the explosion shall be diminished by one or more of the means under 6.5.2 to 6.5.5.

6.5.2. The design of the explosive equipment or facility should consider the maximum explosion pressure or reduced explosion pressure as necessary. Where reduced explosion pressure is considered, the equipment shall be connected to pressure relief or explosion suppression systems.

6.5.3. To protect explosive equipment by relieving the explosion overpressure, hence preventing oversizing otherwise necessary, bursting discs and explosion doors (explosion overpressure relief/venting) may be used. The direction of relief shall be determined in such a way that damage to other structures and hazards to staff can be avoided.

Note:

The standards regulating sizing are MSZ EN 14491 and MSZ EN 14797

6.5.4. Explosive equipment may be fitted with explosion suppression devices according to the relevant standard.

6.5.5. In other closed technology systems, the spread of explosions may be prevented by the following equipment:

f) In the case of gases, vapours and mists:

- f.a) flame arrestors,
- f.b) detonation arrestors,
- f.c) flashback arresters,
- f.d) fire dampers,
- f.e) **flow restrictors and**
- f.f) **explosion barrier valves, dampers**

g) In the case of liquids:

- b.a) **liquid seals**

h) In the case of dusts

- h.a) fire dampers,
- h.b) **IS barriers,**
- h.c) explosion barrier valves, dampers,
- h.d) rotary air lock valve,
- h.e) vent ducts,
- h.f) **pinch valves,**
- h.g) **relief valves,**
- h.h) **Q pipes,**
- h.i) double disc gate valves and
- h.j) **gateways**

¹modified 15.01.2021.

²modified 13.06.2022

6.6 Surfaces and structures to relieve explosion overpressure in the external walls of buildings or rooms

- 6.6.1. Where risk assessment indicates the inability of modes of protection described under 6.3 to 6.5. to provide for the necessary safety level, structures bursting or opening in the case of an explosion shall be used in explosive rooms to reduce the explosion overpressure potentially loading the building structure, thus preventing the building from collapsing.

Note:

Various methodologies define the acceptable risk level in different ways.

- 6.6.2. When sizing the explosion overpressure relief surface, the provisions of Chapter 9 shall apply.

Note:

Methods described in other standards may also be considered for sizing (MSZ EN 14491, MSZ EN 14797).

7. Additional construction criteria for specific cases

Note:

¹In the cases not detailed under 7.1 to 8.8, the provisions of the relevant standards shall apply.

7.1. Passive storage

- 7.1.1. This chapter applies to the passive storage of flammable liquids in sealed factory packaging, in volumes exceeding 300 kg or 300 l, with the exception of aerosols containing liquefied combustible or non-combustible propellants.

Note:

In the case of passive storage, the stored substance shall be prevented from becoming explosive. A substance may become explosive as a result of external factors (outside temperature, direct radiating heat, pressure, etc.)

- 7.1.2. Rooms dedicated for passive storage as defined by this chapter shall comply with all the conditions under 7.1.3 to 7.1.15 or the requirements of the standard series MSZ 15633 'Storing and servicing establishments, equipment of inflammable liquids and easily-meltable. Fire-protection prescriptions.' or those of MSZ 9942 'Storage chamber for inflammable liquids'.

- 7.1.3. In the case of transport containers where at least one of the factory-sealed openings is in contact with the stored combustible liquid (and not only with its vapour), the provisions of this chapter shall not apply.

Note:

Storage in IBC containers is not considered as passive storage; in this case, individual zoning shall apply.

- 7.1.4. During normal operation, zones with a potentially explosive atmosphere will not form in the passive storage room.

- 7.1.5. Explosive substances may only be stored in transport containers that do not erode or get destroyed as a result of the chemical properties of the stored substance, according to the relevant data provided by the manufacturer.

Note:

Potentially explosive atmospheres may only form in the storage room as a result of vapour release due to the failure or destruction of containers.

- 7.1.6. The level of this hazard (i.e. the formation of a potentially explosive atmosphere) may be reduced by using emergency extractor fans actuated by gas detectors that automatically detect hazardous gas concentrations (the rate of emergency extraction shall be calculated according to the expected volume of the explosive atmosphere).

¹modified 15.01.2021.

²modified 13.06.2022

- 7.1.7. Whether a gas detector (detection system) is necessary or not shall be decided according to the potential risks.

Note:

Factors influencing risk levels may include the size of the storage unit (total volume of containers that may malfunction at a time), the material of the containers, the method, quantity and frequency of moving containers etc.

- 7.1.8. In the event of the simultaneous malfunctioning of the two largest transport containers or the destruction of a transport unit, the rate of emergency ventilation or the volume of the space (non-hazardous due to its magnitude) receiving the output of ventilation shall be sized as necessitated by the amount of the hazardous substance entering the room (from the two values, the larger one shall be considered.)
- 7.1.9. ¹Within this room, sampling, dosing, unloading, mixing or **any other manipulation** shall not be allowed.
- 7.1.10. To reduce the risk of leakage, the released substance shall be prevented from escaping the room. To facilitate this, a spill containment sized as necessitated by the amount of the hazardous substance entering the room shall be created, for the event of the simultaneous malfunctioning of the two largest transport containers or the destruction of a transport unit (from the two values, the larger one shall be considered).

Note:

Spill containments may be designed with a suitable sill, gradient etc.

- 7.1.11. ¹The storage room shall contain absorbents in sufficient amount. **The absorbent shall not pose an ignition hazard.**
- 7.1.12. Rooms or interconnected rooms dedicated for passive storage shall be separated from the rooms connected to them but serving other purposes by fire partitions matching the risk classification of the building.

Note:

This form of protection may protect such rooms against external fire, but may also reduce the adverse impacts of internal, non-explosive fires in some cases.

- 7.1.13. In the case of passive storage, bursting or bursting-opening vents may only be used to reduce the adverse impacts of explosion overpressure if the stored substance is prone to self-heating, self-ignition and, consequently, self-explosion. In this case, the walls of the room shall be sized to withstand reduced explosion pressure.

Note:

Wherever possible, one or two side walls of the passive storage room should face an open area.

- 7.1.14. ¹Strong current electric equipment installed in passive storage rooms shall have at least **IP44** protection.

Note:

*¹Explosion proof equipment with a protection level exceeding **IP44** should be used as justified by the results of the relevant risk analysis..*

- 7.1.15. ¹**In passive storage rooms, electric switches, sockets and other electric fitting shall be installed at a minimum height of 0.9 m.**

7.2. Manipulations during storage

- 7.2.1. The design of rooms dedicated to manipulations during storage shall comply with the safety provisions of **7.2.2 to 7.2.4.**

- 7.2.2. ¹In the case of the planned opening of the packaging (mixing, dosing, unloading, offloading, sampling etc.), artificial **ventilation** providing for continuous air replacement as required by normal operation shall be applied where the relevant

¹modified 15.01.2021.

²modified 13.06.2022

calculations demonstrate the inability of passive ventilation to limit the extent of the hazardous zone.

- 7.2.3. ¹The rate of ventilation as required by normal operation to limit the extension of the hazardous zone is determined by calculations, based on the expected volume of the explosive atmosphere.
- 7.2.4. ¹Where necessary, emergency ventilation shall be provided for according to the provisions of 6.4.4.

7.3. Storage and manipulation of dusts

- 7.3.1. Potentially explosive dusts become explosive when their particles are suspended in the air. Accordingly, storing and manipulating such dusts in their closed, factory sealed packaging unit do not pose an explosion hazard.
- 7.3.2. Dust manipulation and dosing as part of the technological process shall be assessed in a case based approach.

¹Note:

The design parameters related to explosive dusts are provided by Annex C.

7.4. Battery charging room

- 7.4.1. ¹The design of battery charging rooms shall comply with the provisions of 7.4.2 to 7.4.6 where the release of explosive gas (hydrogen) is expected due to the nature of the applied technology.
- 7.4.2. The technology of battery charging shall comply with the relevant standards.

Note 1:

As both MSZ 1600-16 and MSZ EN 62485-3 are valid at the moment, it is recommended to apply the provisions of the latest European standard.

Note 2:

When overcharged, lead acid batteries may release hydrogen. According to the relevant standard, VLRA batteries (e.g. gel batteries) may also release hydrogen, but in a lower volume.

Note 3:

Lithium-ion batteries are not expected to release hydrogen during charging.

- 7.4.3. ¹Where the battery charging room or compartment (i.e. dedicated parts of rooms with a large floor area and air volume compared to the technology) is designed according to the relevant standard, zoning is not necessary, due to the continuous ventilation interlocked with the charging technology. Continuous air replacement may be provided for by both passive and artificial ventilation.
- 7.4.4. In the case of batteries within the scope of these provisions, special organisational measures taken within a radius of 0.5 m may provide for compliance with the expected explosion safety levels according to the relevant standard.

Note:

The purpose of these measures may be the elimination of ignition sources.

- 7.4.5. The ventilation rate applied in battery charging rooms or compartments shall be supported by calculations.

¹

- 7.4.6. ²To provide for explosion protection, the floor of battery charging compartments/rooms shall be designed with a leakage resistance as described by Table 2 in Annex 12 of the OTSZ.

Note 1:

¹modified 15.01.2021.

²modified 13.06.2022

¹In practice, this may be provided for by e.g. industrial reinforced and polished concrete structures. However, reinforced concrete is not electrolyte resistant (strong acids), so in cases where electrolyte leakage should be considered, static conductive resins shall be used.

Note 2:

¹Where the battery charging technology complies with the provisions of 7.4.2 to 7.4.6, it is not necessary to use explosion proof products.

Note 3:

The inspections of electric systems shall be performed according to the regulations applying to normal (non-explosive) rooms.

7.5. Natural gas reception terminals (rooms, shafts, cabinets)

7.5.1. ¹The design of these rooms shall comply with the provisions of the Decree 3/2020. (I.13.) ITM the Joint Decree 3/2003. (III.11.) FMM-ESzCsM and 7.5.2 to 7.5.6 of this TvMI regarding explosion safety.

7.5.2. ¹Chapter 7.5 applies to rooms, shafts and cabinets with a flow rate exceeding 40 m³/h and a maximum operating pressure (MOP) of p>100 mbar (medium pressure, high-medium pressure, high pressure), equipped with a **pressure regulator**.

7.5.3. ¹These terminals shall be provided with at least passive ventilation with a lower inlet and upper outlet of a combined surface area corresponding to **at least** 1% of the floor area of the terminal.

7.5.4. ¹If **primary release is not to be considered for a given terminal**, it shall be classified as Zone 2 IIA T1. The zoning of the surrounding areas shall rely on local conditions.

7.5.5. ¹Electrical and non-electrical products (e.g. luminaries, switches, solenoid valves) shall be **designed and installed** to comply with the established zones.

¹

7.5.6. ²To provide for explosion protection, the floor of natural gas terminals shall be designed **as described by Table 2 in Annex 12 of the OTSZ**.

¹Note:

*In practice, this is provided for by industrial reinforced concrete structures and **certified industrial floors**.*

7.6. Rooms with natural gas burners

7.6.1. ¹Concerning rooms where natural gas is burnt and

a) ²include a gas consuming appliance of a unit heat input as defined by the Decree 3/2020.(I.13.) ITM (Point 26.8. of Annex 1, at the time of issue of the TvMI)

b) ²include gas consuming appliances of a combined heat input as defined by the Decree 3/2020.(I.13.) ITM (Point 26.8. of Annex 1, at the time of issue of the TvMI) or

c) ²include a **gas consuming technology** of a unit heat input as defined by the Decree 3/2020.(I.13.) ITM (Point 26.8. of Annex 1, at the time of issue of the TvMI)

their design shall comply with the provisions of **the Decree 3/2020. (I.13.) ITM the Joint Decree 3/2003. (III.11.) FMM-ESzCsM and 7.5.2 to 7.5.6 of this document** regarding explosion safety.

7.6.2. The primary aim is to prevent the formation of dangerous gas concentrations in these rooms, therefore they shall be equipped with a gas detector with redundancy (or gas detection systems).

7.6.3. ¹To provide for a prompt response, gas detectors installed in the vicinity of or over locations where gas release is expected shall be selective for the **gas concerned** and equipped with a collecting hood.

¹modified 15.01.2021.

²modified 13.06.2022

- 7.6.4. ¹The operation of the gas detection system shall comply with the provisions of 6.4.4 under the condition that the inlet and the outlet of the ventilation system are located in the lower third of the room and near the ceiling, respectively.
- 7.6.5. ¹In the case of pressurised ventilation, the generation of a hazardous gas flow towards the door shall be prevented. Accordingly:
- a) the door shall open inwards (against the pressure) and be of a self-closing design or
 - b) when the door opens outwards, the room including the natural gas burner shall be connected to other rooms via an airlock.

Note:

If the desired level of safety cannot be guaranteed using the technical solutions described above, airtight doors may be used (e.g. smoke doors)

- 7.6.6. The floors and walls of these rooms are not considered as ignition sources; specific explosion protection provisions do not apply.

7.7. ¹Paint booths, rooms with spraying walls

- 7.7.1. ¹The design of paint booths and rooms with spraying walls shall comply with the provisions of 7.7.2 to 7.7.5 regarding the positioning of the technology.
- 7.7.2. ¹When installing paint booths and rooms with spraying walls, the relevant product standards shall also be considered in addition to the manufacturer's specifications.

Note:

¹Concerning paint booths and spraying walls, the relevant standard at the moment is MSZ EN 16985.

- 7.7.3. ¹If the painting booth or spraying wall qualifies as a flammable or potentially explosive machine, device or piece of equipment, fire safety certification is mandatory. Where the design qualifies as a flammable or potentially explosive technology, compliance shall be certified according to § 20 (2) of Act XXXI of 1996 (see 5.3.2 of this TvMI).

Note:

§4d) of Act XXXI of 1996 defines fire safety conformity certificate: A document issued by a designated Hungarian certification body or a notified body listed by the European Commission for the performance of conformity assessments, which certifies that the fire-fighting technical product or the flammable or explosive device, machine or piece of equipment complies with the fire protection provisions specified in the fire protection and safety requirements.

¹

- 7.7.4. ^{1,2}To provide for explosion protection, the floor of paint booths and spraying walls within zones with potentially explosive atmospheres shall be designed with a maximum leakage according to Table 2 of Annex 12 of the OTSZ. In practice, this is provided for by industrial reinforced concrete floors or galvanised steel mesh flooring.
- 7.7.5. ¹The regular cleaning of the floors concerned shall be provided for (due to the detrimental effect of paint build-up on leakage resistance).

Note:

As the floor shall have a maximum leakage resistance of 100 MΩ at all times, potential contamination shall be considered already in the design phase and the leakage resistance sized accordingly. The structures recommended under 8.7.5 provide for a resistance better than this by several orders of magnitude, meeting the provisions applying to the design of these floors.

8. Sizing the surface of relief vents

- 8.1. This chapter prescribes the criteria for designing the surface of explosion relief vents relieving the overpressure of potential unconfined explosions or other explosions not

¹modified 15.01.2021.

²modified 13.06.2022

caused by explosives, applicable in the cases specified by the relevant legislation and technical regulations.

- 8.2. 1The facilities protected by relief vents include:
- a) technological equipment (distillers, sawdust extractors in carpentry, dust separators, bucket elevators, chain conveyors)
 - b) buildings (e.g. silos)
 - c) rooms (typically rooms where the risk of explosion under normal operating conditions may not be reduced to an acceptable level either by the design tools described under 3.2 of this TvMI or risk analysis).

1Note:

Where protection in the direction of relief cannot be provided for (e.g. in particular rooms, in urban environments or in an unbroken row of buildings), it is recommended to use suitable explosion prevention design and construction methods instead of bursting or bursting-opening vents, if the relevant regulations allow.

- 8.3. 1Where relief vents are used, other boundary structures for buildings, installations or equipment shall be able to withstand the reduced explosion pressure in the protected area (equipment, installation, building) which is formed despite normal explosion relief.

1Note:

The pressure resistance of major constructed structures are as follows:

- *Window panes: 0.02-0.07 bar*
- *Doors: 0.02-0.05 bar*
- *Wired glass: 0.06-0.065 bar*
- *Metal structures: 0.1-0.4 bar*
- *Not reinforced, 20 cm thick concrete structures: 0.15-0.2 bar*
- *Reinforced concrete structures: size dependent, typically 0.5 – 2.0 bar*

- 8.4. 1According to 8.12 of this TvMI, the surroundings in the direction of relief shall be protected.

- 8.5. 1Where necessary, bursting or opening (bursting-opening) vents shall have a design that prevents the propagation of explosions, or it is recommended to verify that adjacent buildings, structures and technological equipment in the direction of relief are installed at a safe distance by calculating the length of the flame exiting the relief vent.

1Note:

The distance calculated in this way may exceed the minimum fire safety distance specified in Annex 3 of the OTSZ. In such cases, the direction of relief shall be changed or the distance increased.

- 8.6. 1In the case of explosive equipment or buildings, back pressure supporting shall be provided for, i.e. a surface which opens at the same time as the opening (bursting-opening) vent to prevent depression in the equipment or building after explosion relief. (It is particularly important where self-closing vents are applied).

- 8.7. 1Relief vents for explosion overpressure are as follows:

- 8.7.1. 1Bursting vents with a structure that is destroyed by overpressure, thus providing an opening to relieve the overpressure inside:

- a) burst discs, burst panels, typically designed for technological equipment and buildings (bursting panel devices, pop-out panel devices),
- b) single layer building structures described in former regulations and standards.

- 8.7.2. 1Opening (bursting-opening) vents that provide an opening to relieve the overpressure inside by opening up, flapping or turning; the opening pressure for these is adjustable. These include:

- a) self closing vents (opening or bursting-opening);

¹modified 15.01.2021.

²modified 13.06.2022

b) manually closed vents (opening or bursting-opening).

- 8.8. ¹The opening pressure for bursting or bursting-opening vents shall be tested and verified by standardised methods.

¹Note:

The opening pressure cannot be calculated by mathematical or architectural calculations only; the standardised tests cannot be replaced by these. The reduced explosion overpressure generated in the protected space is defined by the opening pressure and the timeframe of venting together.

8.9. **1 Calculating the surface of relief vents**

- 8.9.1. ¹The surface of relief vents may be calculated as follows:

¹Note:

In most cases the relevant standards shall apply. For cases outside the scope of these (e.g. tubular spaces), customised and validated sizing methods shall be used.

- 8.9.1.1. ¹For potential dust explosions, MSZ EN 14797 shall apply, with the following main steps:

- a) Determining the K_{st} maximum rate of explosion pressure rise and the P_{max} maximum explosion pressure for the potentially explosive dust by experiments;
- b) Verifying the boundary conditions for the space designed with a bursting or opening (bursting-opening) vent to relieve explosion overpressure:
 - volume,
 - maximum explosion pressure as a function of the K_{st} maximum rate of explosion pressure rise,
 - static opening pressure for the bursting or opening (bursting-opening) vent,
 - length/diameter (L/D) ratio of the space to be protected,
 - ambient conditions (temperature, oxygen concentration etc.);
- c) Calculating the surface of the bursting or opening (bursting-opening) vent;
- d) Selecting a bursting or opening (bursting-opening) vent from those with available test results.

- 8.9.1.2. ¹For potential gas, vapour or mist explosions, MSZ EN 14994 shall apply, with the following main steps:

- a) Determining the K_G maximum rate of explosion pressure rise and the maximum explosion pressure for the potentially explosive gas, vapour or mist;
- b) Verifying the boundary conditions for the space designed with a bursting or opening (bursting-opening) vent to relieve explosion overpressure:
 - the examined space is free of turbulence,
 - maximum rate of explosion pressure rise (K_G),
 - volume,
 - reduced explosion overpressure,
 - static opening pressure for the bursting or opening (bursting-opening) vent,
 - length/diameter (L/D) ratio of the space to be protected,
 - ambient conditions (temperature, oxygen concentration etc.);
- c) Calculating the surface of the bursting or opening (bursting-opening) vent;
- d) Selecting a bursting or opening (bursting-opening) vent from those with available test results.

¹modified 15.01.2021.

²modified 13.06.2022

8.9.1.3. ¹In the case of natural gas- air mixtures or gases, vapours or mists not covered by the scope of MSZ EN 14994, the surface of bursting vents shall be defined according to the results of *Calculation 1*, without having to consider the special cases detailed under 8.10.

Calculation 1

$$A_h = f_h \times V$$

where: A_h surface of the bursting vent [m²]
 f_h specific bursting surface factor [m²/m³]
 V free volume in the room [m³]

for $V \leq 200 \text{ m}^3$

$$f_h = 0.2 - \frac{0.05 \cdot V}{200}$$

for $200 \text{ m}^3 < V \leq 2\,000 \text{ m}^3$

$$f_h = 0.15 - \frac{0.05 \cdot (V - 200)}{1800}$$

for $2\,000 \text{ m}^3 < V \leq 10\,000 \text{ m}^3$

$$f_h = 0.10 - \frac{0.045 \cdot (V - 2000)}{8000}$$

for $10\,000 \text{ m}^3 < V \leq 100\,000 \text{ m}^3$:

$$f_h = 0.055 - \frac{0.040 \cdot (V - 10000)}{90000}$$

for $100\,000 \text{ m}^3 < V \leq 500\,000 \text{ m}^3$

$$f_h = 0.015 - \frac{0.005 \cdot (V - 100000)}{400000}$$

over $500\,000 \text{ m}^3$

$$f_h = 0.01$$

8.9.1.4. ¹In the case of natural gas-air mixtures or gases, vapours or mists not covered by the scope of MSZ EN 14994, the surface of opening vents shall be defined according to the results of *Calculation 2*, without having to consider the special cases detailed under 8.10.

8.9.1.4.1. The opening pressure of the opening vents shall not exceed 110% of the expected wind suction at the installation location, unless other demands (burglary prevention, technological overpressure etc.) justify otherwise.

Calculation 2

$$A_{hn} = f_{hn} \times V$$

where: A_{hn} surface of bursting vent [m²]
 f_{hn} specific bursting surface factor [m²/m³]
 V free volume in the room [m³]

for $V \leq 200 \text{ m}^3$

¹modified 15.01.2021.

²modified 13.06.2022

$$f_{hn} = 0.15 - \frac{0.05 \cdot V}{200}$$

for $200 \text{ m}^3 < V \leq 2\,000 \text{ m}^3$

$$f_{hn} = 0.10 - \frac{0.05 \cdot (V - 200)}{1800}$$

for $2\,000 \text{ m}^3 < V \leq 10\,000 \text{ m}^3$

$$f_{hn} = 0.05 - \frac{0.02 \cdot (V - 200)}{8000}$$

for $10\,000 \text{ m}^3 < V \leq 100\,000 \text{ m}^3$

$$f_{hn} = 0.03 - \frac{0.02 \cdot (V - 100\,000)}{90000}$$

for $100\,000 \text{ m}^3 < V \leq 500\,000 \text{ m}^3$

$$f_{hn} = 0.01 - \frac{0.005 \cdot (V - 100\,000)}{400\,000}$$

over $500\,000 \text{ m}^3$

$$f_{hn} = 0.004$$

8.10. Special cases

- 8.10.1. In the case of rooms at least four times as long as wide, the value yielded by *Calculations 1 and 2* shall be increased by 20%.
- 8.10.2. In exceptional cases, the relief vent may open into a confined reception space if the explosion pressure inside a room cannot be relieved in any other way. In such cases, the volume of the reception space shall be equal to at least five times that of the relieved room and shall have a bursting or opening vent opening to the outside.
- 8.10.3. ¹Basement lightwells may also be used for explosion pressure relief where the geometry of the walls of the shaft comply with the provisions of 8.12.4, 8.12.6 a) or b) and 8.12.7 regarding the direction of relief.
- 8.10.4. Where bursting and opening vents are combined and the combined surface area of bursting-opening vents does not reach that of the bursting vents or the opening pressure exceeds 1 kN/m^2 , their total surface shall be defined according to the results of *Calculation 1*.
- 8.10.5. Where bursting and opening vents are combined and the surface of the opening vents reaches or exceeds that of the bursting vents, their total surface shall be defined according to the results of *Calculation 2*.
- 8.10.6. Where the opening pressure of the bursting-opening vents falls between 1 and 3 kN/m^2 , the surface shall be defined according to the results of *Calculation 1*.

8.11. Protection against secondary explosions

- 8.11.1. The vents for pieces of equipment explosive by themselves and posing a secondary explosion hazard to their environment when malfunctioning shall open into spaces different from those threatened by the secondary explosion.

8.12. Protection of the environment of vents

- 8.12.1. To protect circulation routes and public spaces, vents shall be installed on the roof wherever possible.

¹modified 15.01.2021.

²modified 13.06.2022

- 8.12.2. ¹When the vents cannot be installed on the roof, they may also be installed in side walls; in that case, the provisions of 8.12.3 to 8.12.7 shall apply.
- 8.12.3. ¹The safety distance in the direction of relief shall be defined according to Fig. 5.

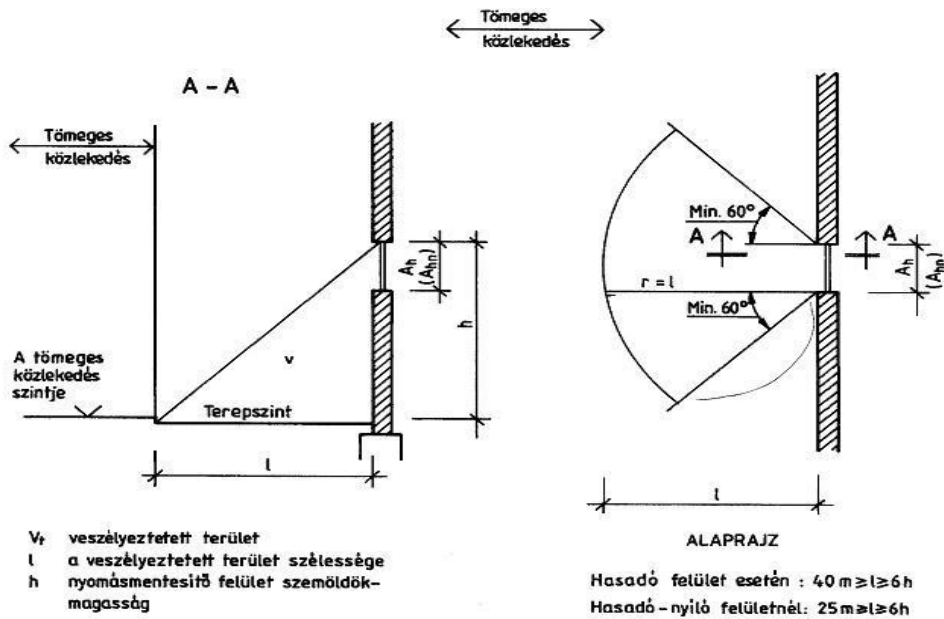

Tömeges közlekedés	Circulation route
Tömeges közlekedés szintje	Level of circulation route
Terepszint	Ground level
Veszélyeztetett terület	Threatened area
Nyomásmentesítő felület szemöldök-magasság	Relief vent's lintel height
Alaprajz	Floor plan
Hasadó felület esetén	For bursting vents
Hasadó-nyíló felület esetén	For bursting-opening vents

Fig. 5

- 8.12.4. Public spaces or circulation routes other than those within the plant may only be established within the safety distance of vents when they are protected by protective walls, deflector walls or bursting-opening vents presuming the direction of relief does not pose a threat.
- 8.12.5. ¹Protective walls and deflector walls shall prevent the relief from threatening public spaces or circulation routes other than those within the plant as provisioned by Fig. 6.

¹modified 15.01.2021.

²modified 13.06.2022

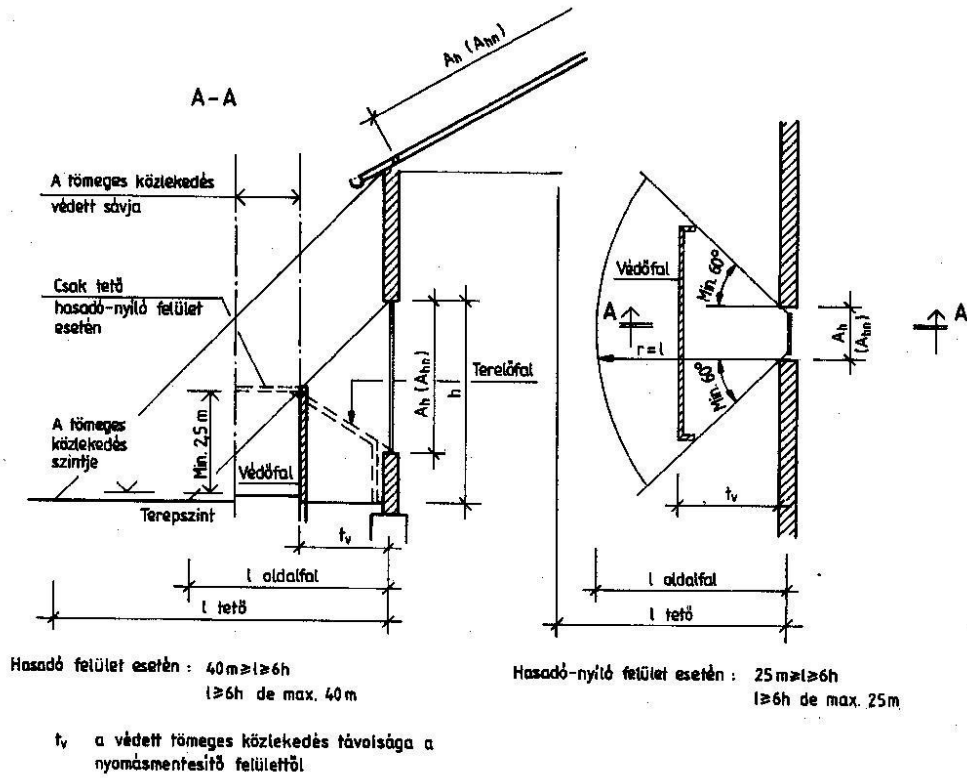

Tömeges közlekedés védett sávja	Safety zone for circulation route
Tömeges közlekedés szintje	Level of circulation route
Tető	Roof
Terepszint	Ground level
Csak tető Hasadó-nyíló felület esetén	Only for bursting-opening vents installed on the roof
Védőfal	Protective wall
Terelőfal	Deflector wall
Oldalfal	Side wall
Alaprajz	Floor plan
Hasadó felület esetén	For bursting vents
Hasadó-nyíló felület esetén	For bursting-opening vents
Védett tömeges közlekedés távolsága a nyomásmentesítő felülettől	Distance between the protected circulation route and the relief vent

Fig. 6.

8.12.6. Protective walls and deflector walls shall be designed in a way that they do not interfere with the relief and sufficient space is provided for venting

a) $\gamma \max 60^\circ$ according to Fig. 7,

¹modified 15.01.2021.

²modified 13.06.2022

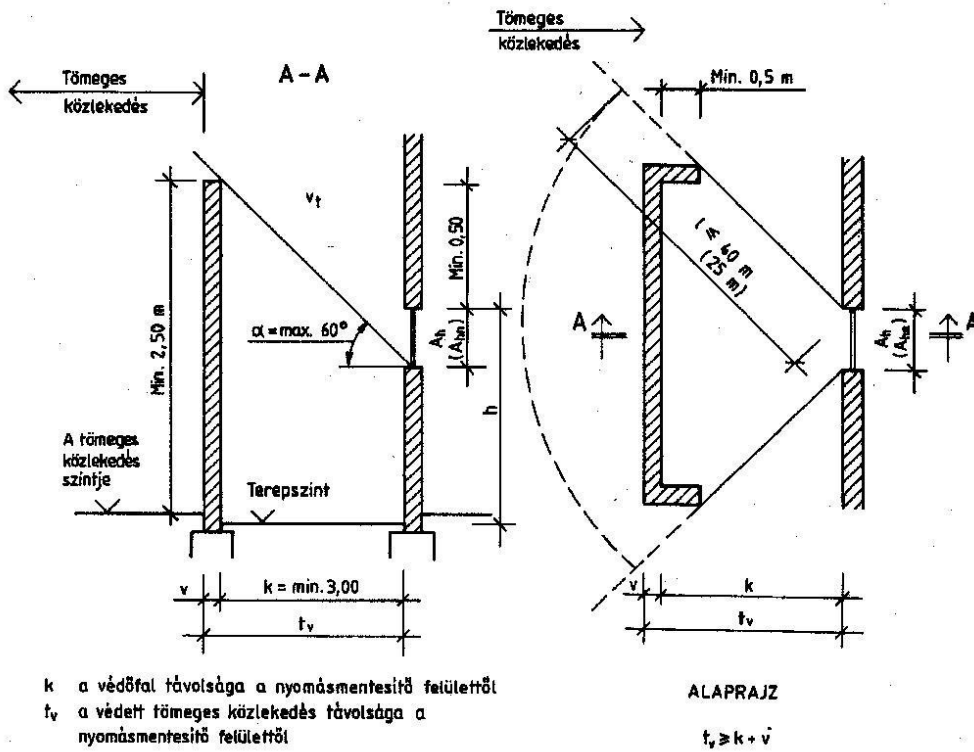

Tömeges közlekedés	Circulation route
Tömeges közlekedés szintje	Level of circulation route
Terepszint	Ground level
Alaprajz	Floor plan
Védett tömeges közlekedés távolsága a nyomásmentesítő felülettől	Distance between the protected circulation route and the relief vent
Védőfal távolsága a nyomásmentesítő felülettől	Distance between the protective wall and the relief vent

Fig. 7

b) $\alpha \max 30^\circ$, according to Fig. 8,

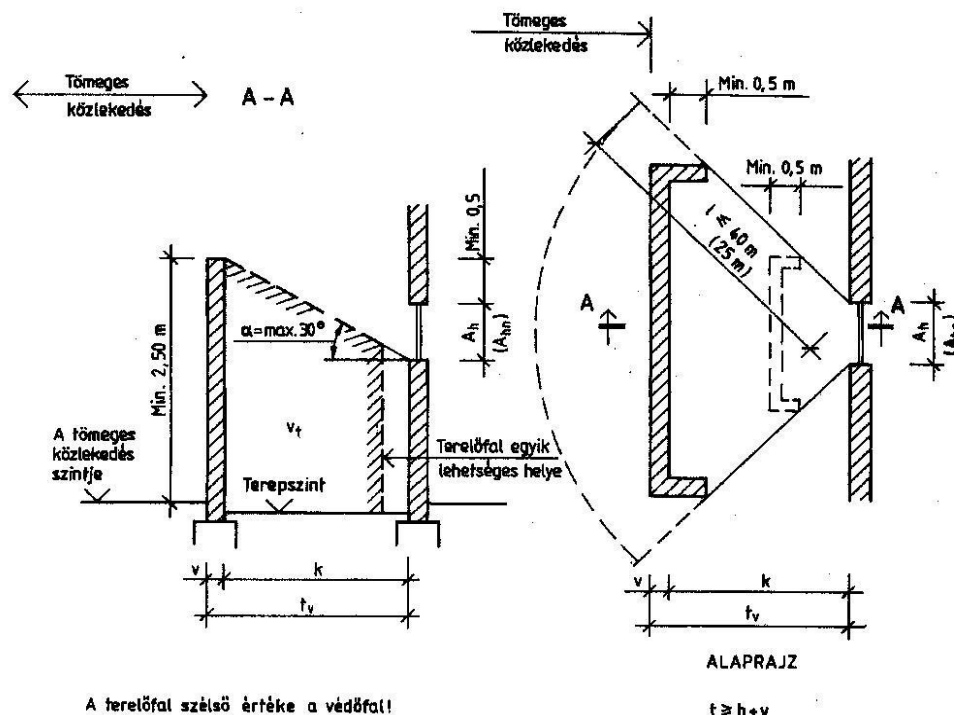

¹modified 15.01.2021.
²modified 13.06.2022

Tömeges közlekedés	Circulation route
Tömeges közlekedés szintje	Level of circulation route
Terepszint	Ground level
Alaprajz	Floor plan
Terelőfal egyik lehetséges helye	Potential location for the deflector wall
A terelőfal szélső értéke a védőfal!	The extreme value of the deflector wall is the protective wall

Fig 8

c) $\alpha \leq 30^\circ$ by a supplementary angle of minimum 60° according to Fig. 9

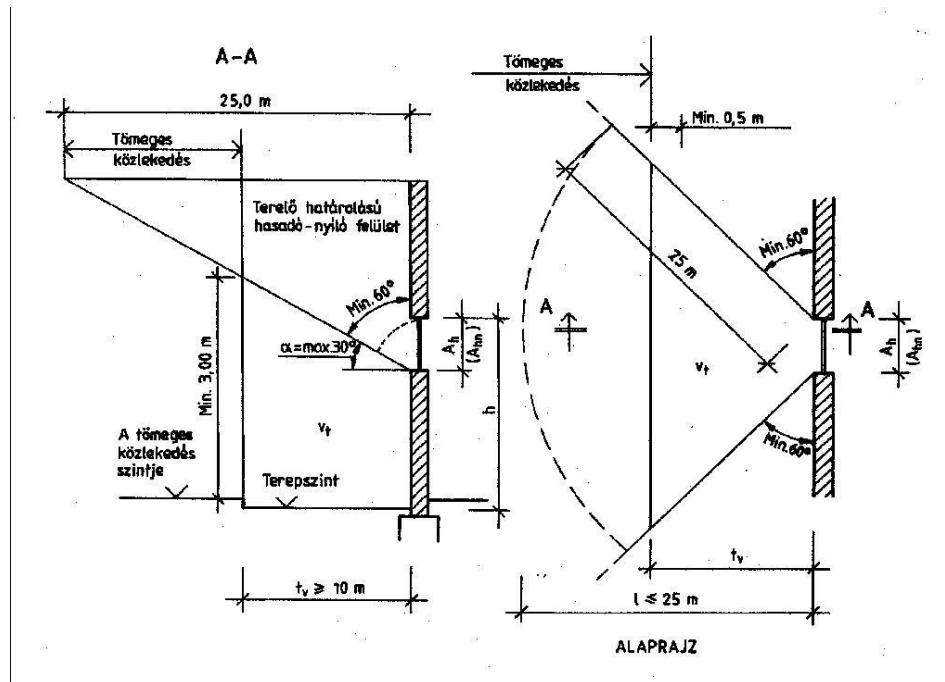

Tömeges közlekedés	Circulation route
Tömeges közlekedés szintje	Level of circulation route
Terepszint	Ground level
Alaprajz	Floor plan
Terelő hatású hasadó-nyíló felület	Bursting-opening vent also serving as a deflector

Fig. 9

8.12.7. Where the circulation route to be protected is routed by a building containing a potentially explosive atmosphere and equipped with a roof vent, the following shall apply:

- For bursting vents, the safety distances are calculated according to 8.12.3 and 8.12.5;
- In the case of bursting or opening vents where the relief threatens other structures due to its direction, the safety distance shall be defined according to Fig. 10;

¹modified 15.01.2021.
²modified 13.06.2022

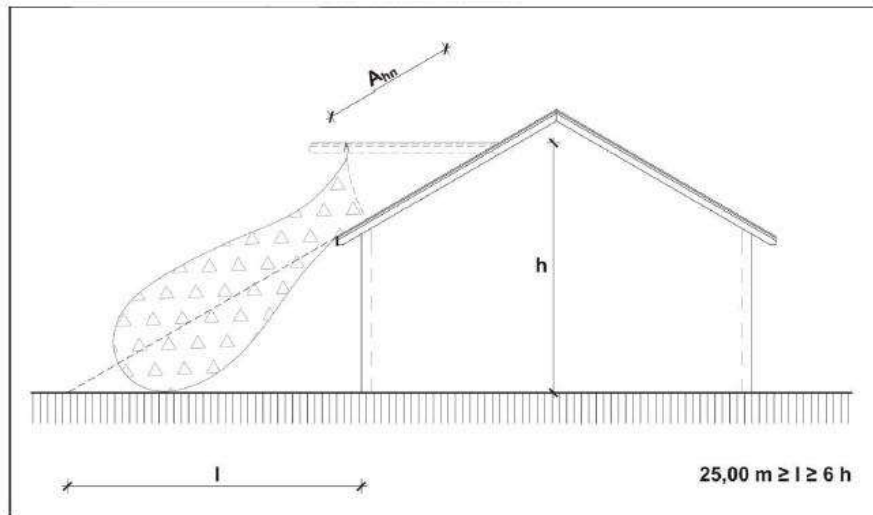

Fig. 10

c) ¹In the case of bursting or opening surfaces where the relief does not threaten other structures due to its direction and the side wall vents facilitate this, the safety distance shall be 8.00 m as illustrated by Fig. 11.

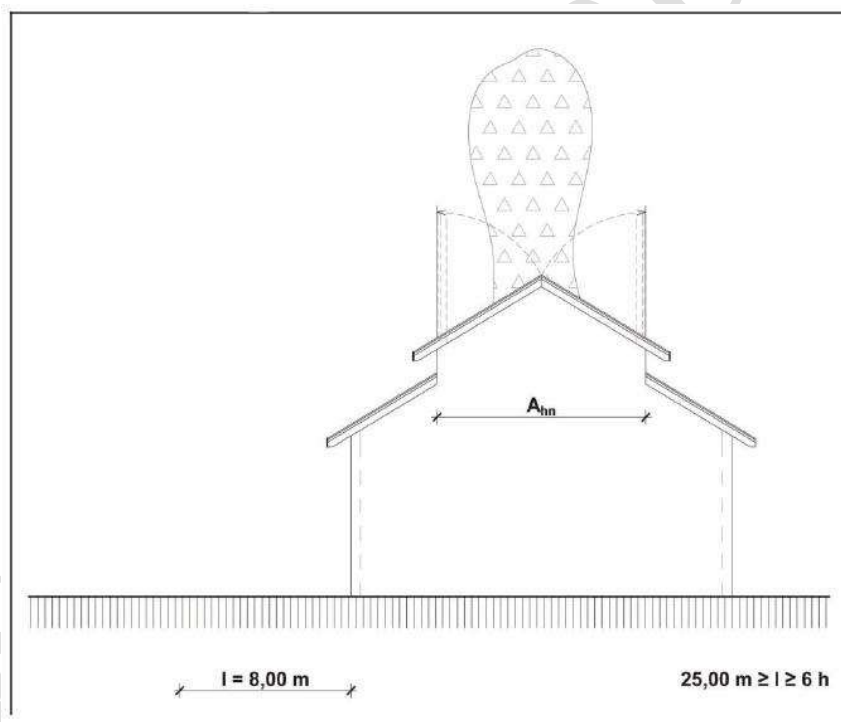

Fig. 11.

- 8.12.8. ¹Doors/windows and buildings/building sections may not be installed within 10 m and 6 m of the opening of the vent, measured along the direction of the relief, respectively. Built structures beyond these safety distances shall be sized according to 8.12.7.
- 8.12.9. ¹In the case of equipment installed within 3 m in front of bursting of opening vents, the surface area considered as covered by this equipment (calculated with a 60° projection angle as illustrated by Fig. 12.) shall be ignored when calculating the vent surface.

¹modified 15.01.2021.

²modified 13.06.2022

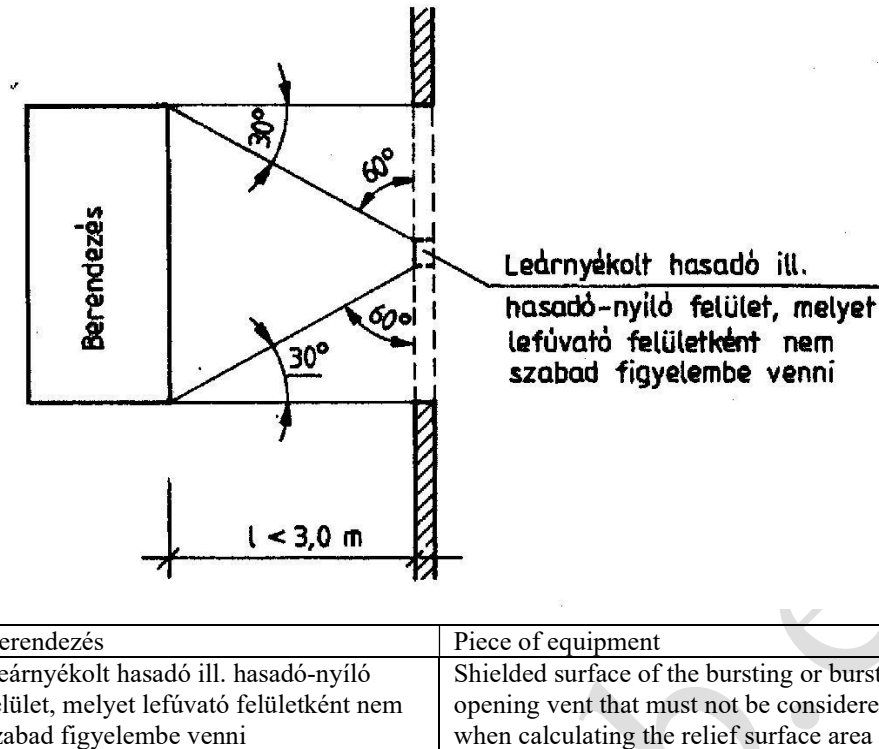

Fig 12

- 8.12.10. If a piece of equipment is installed within 6 m of the relief vent in the direction of relief, it shall be sized in a way that it can withstand the relief pressure loading the deflector.
- 8.13. **Loads on built structures**
- 8.13.1. ¹Where bursting vents described under 8.9.1.3 are used, the extra static load on primary supporting structures in the inner space of the building shall be calculated as 3 kN/m² in each direction.
- 8.13.2. ¹Where bursting-opening vents described under 8.9.1.4 are used, the extra static load on primary supporting structures in the inner space of the building shall be calculated as 2 kN/m² in each direction.
- 8.13.3. ¹Where opening vents described under 8.13.2 are used or the opening vents are installed on low pressure equipment, the reduced explosion pressure shall be considered for a duration of 0.02 sec or using a pressure vs time graph.
- 8.13.4. Bursting and opening vents shall be evenly distributed on the boundary surfaces or concentrated where explosions are expected. The distance between bursting vents shall not exceed 12 m within the space to be relieved.
- 8.13.5. The supporting structures of the space to be protected by bursting and opening vents shall be designed in a way that the failure of any element cannot result in a progressive collapse.
- 8.13.6. Efforts shall be made to prevent secondary support structures from overloading primary structures, allowing the former to only transfer limited loads to the latter.
- 8.13.7. Static loads in the direction of relief to be considered when sizing protective walls and deflectors as a function of their distance from the vents:
- Within 5 m: 6 kN/m²,
 - Between 5 and 10 m: 5 kN/m²,
 - Between 10 and 20 m: 3 kN/m²,

¹modified 15.01.2021.²modified 13.06.2022

d) Beyond 20 m: 1kN/m²

Due to the suction effect, 20% of the loads specified above shall be considered in the direction opposite to that of the relief.

9. Criteria for positioning gas detectors

- 9.1. ¹One of the goals when designing gas detectors for a facility may be to increase the level of personal safety of employees. In this case, employees and those working in the area shall leave the building or the space outside upon perceiving the light and sound alarm signals of the gas detector. The other main goal may be to limit the extension of the zone with potentially explosive atmosphere; in this case the reliable operation of the technology shall be secured by positive engagements to be considered as early as the design phase.
- 9.2. ¹If the design goal is to modify the protection level of the equipment used in the given potentially explosive atmosphere or the space itself where the potentially explosive atmosphere is present, the design of gas detectors shall be preceded by the hazard and risk analysis of the technology. This goal may only be achieved by using installed detector systems.
- 9.2.1. ¹The analysis shall cover the cases, malfunctions and scenarios that may result in unwanted releases, as well as the physical parameters of such releases (e.g. pressure, temperature) in these cases.
- 9.2.2. ¹The analysis shall include the interventions where efficient protection may be provided by installed gas detector systems and details whether the particular intervention is aimed at reducing releases or to facilitate measures that reduce the size of the area characterized by the resulting explosive concentration.
- 9.2.3. ¹The analysis shall determine the reliability of the gas detection system (detector, signal transmission, signal processing and intervention units) that provides protection. This reliability shall be considered when designing the gas detection system.
- 9.3. ¹If the design goal is to increase the level of personal protection, the use of both installed and portable detectors may be considered.
- 9.4. ¹The location of the installed gas sensors shall comply with the requirements of 9.4.1 to 9.4.3 and 9.5.
- 9.4.1. ¹When selecting and positioning gas detectors to continuously measure the concentration of combustible gases/vapours in spaces with a potentially explosive atmosphere, the following considerations shall apply:
- a) the type and operating principle of the gas detector;
 - (b) the physical and chemical properties of the gases/vapours to be detected (e.g. relative density);
 - (c) the zoning of the area with the potentially explosive atmosphere;
 - (d) in the case of outdoor technologies, wind direction (also considering the objects affecting it);
 - e) in the case of a confined spaces, the ventilation;
 - (f) the parameters of the technology used;
 - (g) any other factor that may affect the efficient operation of the installed gas detectors.
- 9.4.2. ¹For efficient gas detection:
- a) at least two gas detectors shall be installed to protect the technology (the system shall be designed with a redundancy);

¹modified 15.01.2021.

²modified 13.06.2022

- b) redundant systems shall be installed that comply with the relative density of the gases to be detected (at least two gas sensors shall be used for gases/vapours whose relative density is lower equal to or higher than that of the air, respectively);
- c) the functional safety of the installed gas detector is provided for in accordance with the relevant standard,

Note 1:

Regarding functional safety, MSZ EN 61508, MSZ EN 61511 and MSZ EN 60079-29-3 shall be considered.

- d) gas detectors shall be selected considering the explosive substances relevant to the technology,
- e) the coverage shall be determined according to the required level of safety, also considering the manufacturer's specifications and design considerations specific for the technology;

Note:

The installation of at least one gas detector for each 20 m² is recommended.

- f) the gas detector complies with the requirements of the given zone (quality, gas group, temperature class)
- g) gas detectors shall be installed considering the wind or any other air current (ventilation) that may effect the spreading of the gas cloud.

¹Note 1:

In Zone 0 areas, gas detectors are only needed when their use is expressly provisioned for the given technology and the mode of protection of the gas detector allows it.

¹Note 2:

Installed gas detectors may not be replaced by using personal, manual or portable gas detectors.

9.4.3. ¹For efficient alarm:

- a) when the alarm is triggered by the concentration of the gas, sound and light signals well audible and visible in the technological area shall be made,
- b) when determining triggering concentrations, the sampling frequency of the particular detector sensor, sampling duration, signal transmission and processing times and the time needed for potential interventions shall be considered, also taking into account the assumed rate of increase of concentration in the given space.

Note:

In confined spaces, the time to reach the critical concentration may be calculated according to C.3.6.2 'Background concentration and releases in ventilated rooms' of MSZ EN 60079-10-1:2016 Explosive atmospheres. Part 10-1: Classification of areas. Explosive gas atmospheres (IEC 60079-10-1:2015 + COR1:2015).

9.5. ¹For the compliant operation of gas detectors:

- a) when the triggering concentration of gas detectors is reached (max. LFL 25%), the people present in the technological area shall be warned by a light signal;

Note 1:

Where the gas detector also controls ventilation, the lower action level shall be set at least LFL 20% in accordance with the OTSZ provisions.

Note 2:

The standards and regulations concerning gas detectors consider LFL (lower flammable limit) and UFL (upper flammable limit) values instead of LEL and UEL.

- b) when the triggering concentration of gas detectors is reached (max. LFL 50%), the people present in the technological area shall be warned by sound and light signals;

Note:

At LFL 25% and LFL 50%, the colour of the light signal is yellow and red, respectively.

¹modified 15.01.2021.

²modified 13.06.2022

- c) when the LFL 50% triggering concentration of gas detectors is reached, interlocked systems shall start operating when required by the hazard level and allowed by the technology,

Note:

Interlocked functions may include:

- *the closing of explosion barrier valves in the technology,*
 - *the shutting off of the explosion proof electric equipment defined by technologists and installed outside zones with potentially explosive atmospheres where the technology allows, except for explosion proof luminaries, ventilation systems and gas detection systems,*
- *ventilation control*
- *emergency unloading.*

- d) the signal processing/evaluation/display/acknowledgment units of installed gas detectors shall be installed in a room outside zones with potentially explosive atmospheres.

Note:

If the application of installed gas detectors is a prerequisite for the safe operation of an explosive technology and detection operates without human supervision, the remote monitoring of the installed gas detectors shall be provided for in addition to the local sound and light signal in case of hazardous technological systems.

¹modified 15.01.2021.

²modified 13.06.2022

Legislation and standards referred in the Guideline

Referred legislation

Act XXXI of 1996 on Fire Protection, Technical Rescue And Fire Brigades (Ttv)

Act XCIII of 1993 on Occupational Safety and Health (Mtv)

Decree 54/2014. (XII.5.) BM on the National Fire Protection Regulations (OTSZ)

Decree 21/2010. (V.14.) NFGM on the qualifications for certain industrial and commercial activities.

¹Decree 3/2020. (I.13.) ITM on technical safety standards for connection pipelines, user equipment, on-site pipelines, oil consuming technological systems and gas storage facilities, the professional qualifications and experience required for positions with a relevance to technical safety and on the rules for the periodic training of employees in such positions, amending the Decree 16/2018. (IX.11.) ITM

Joint Decree 3/2003. (III.11.) FMM-ESzCsM on the minimum requirements for improving the safety of workers potentially at risk from explosive atmosphere

Decree 4/2001(II. 23.) GM on the minimum level of safety and health protection requirements to be implemented in mining plants

¹Decree 34/2014. (X.30.) NGM on the requirements for the marketing of aerosols and aerosol packaging

¹Decree 35/2016. (IX.27.) NGM on examination and certification of equipment and protective systems intended to use in potentially explosive area

¹Decree 40/2017. (XII.4.) NGM on connecting and user equipment and electric equipment and protective systems intended for use in potentially explosive atmospheres

¹Decree 22/2009. (VII.23.) ÖM on the rules of obtaining fire prevention certificates of compliance

¹Govt. Decree 266/2013. (VII.11.) on construction and the practicing of related professions

¹Decree 21/2010. (V.14.) NFGM on the qualifications for certain industrial and commercial activities

Referred standards

Note:

For the application of this TvMI, the standards in effect shall apply. The standards listed below are in effect at the time of the publication of this TvMI: Dates of publication are indicated.

¹MSZ EN 1127-1:2019 Explosive atmospheres. Explosion prevention and protection. Part 1: Basic concepts and methodology

MSZ EN 1127-2:2014 Explosive atmospheres. Explosion prevention and protection. Part 2: Basic concepts and methodology for mining

MSZ EN 13237:2013 Potentially explosive atmospheres. Terms and definitions for equipment and protective systems intended for use in potentially explosive atmospheres

²MSZ EN IEC 60079-10-1:2021 Explosive atmospheres. Part 10-1: Classification of areas. Explosive gas atmospheres

MSZ EN 60079-10-2:2015 Explosive atmospheres. Part 10-2: Classification of areas. Explosive dust atmospheres

¹MSZ EN IEC 60079-0:2018 Explosive atmospheres. Part 0: Equipment. General requirements

MSZ EN 60079-1:2015 Explosive atmospheres. Part 1: Equipment protection by flameproof enclosures "d"

MSZ EN 60079-2:2015 Explosive atmospheres. Part 2: Equipment protection by pressurized enclosure "p"

MSZ EN 60079-5:2015 Explosive atmospheres. Part 5: Equipment protection by powder filling "q"

MSZ EN 60079-6:2016 Explosive atmospheres. Part 6: Equipment protection by liquid immersion "o"

MSZ EN 60079-7:2016 Explosive atmospheres. Part 7: Equipment protection by increased safety "e"

MSZ EN 60079-11:2012 Explosive atmospheres. Part 11: Equipment protection by intrinsic safety "i"

MSZ EN 60079-14:2014 Explosive atmospheres. Part 14: Electrical installations design, selection and erection

MSZ EN IEC 60079-15:2019 Explosive atmospheres. Part 15: Equipment protection by type of protection "n"

¹modified 15.01.2021.

²modified 13.06.2022

MSZ EN 60079-17:2014 Explosive atmospheres. Part 17: Electrical installations inspection and maintenance

MSZ EN 60079-18:2015 Explosive atmospheres. Part 18: Equipment protection by encapsulation "m"

¹MSZ EN IEC 60079-19:2020 Explosive atmospheres. Part 19: Equipment repair, overhaul and reclamation

¹

MSZ EN 60079-25:2011 Explosive atmospheres. Part 25: Intrinsically safe electrical systems

MSZ EN 60079-26:2015 Explosive atmospheres. Part 26: Equipment with Equipment Protection Level (EPL) Ga

MSZ EN 60079-28:2016 Explosive atmospheres. Part 28: Protection of equipment and transmission systems using optical radiation

MSZ EN 60079-29-1:2017 Explosive atmospheres. Part 29-1: Gas detectors. Performance requirements of detectors for flammable gases

MSZ EN 60079-29-2:2015 Explosive atmospheres. Part 29-2: Gas detectors. Selection, installation, use and maintenance of detectors for flammable gases and oxygen

²MSZ EN 60079-29-3:2014 Explosive atmospheres. Part 29-3: Gas detectors. Guidance on functional safety of fixed gas detection systems (IEC 60079-29-3:2014)

MSZ EN 60079-30-1:2017 Explosive atmospheres. Part 30-1: Electrical resistance trace heating. General and testing requirements

MSZ EN 60079-30-2:2017 Explosive atmospheres. Part 30-2: Electrical resistance trace heating. Application guide for design, installation and maintenance

¹

MSZ EN 62485-3:2015 Safety requirements for secondary batteries and battery installations. Part 3: Traction batteries

MSZ 1600-16:1992 Wiring rules for the establishment of power current installations up to 1000 V. Installation rules for stationary batteries, battery rooms and charging stations

MSZ 15633 series. Storing and servicing establishments, equipment of inflammable liquids and easily-meltable. Fire-protection prescriptions.

MSZ 9942:1983 Storage chamber for inflammable liquids.

MSZ EN 16985:2019 Spray booths for organic coating material. Safety requirements

¹MSZ EN 1539:2016 Dryers and ovens, in which flammable substances are released. Safety requirements

MSZ EN 14491:2013 Dust explosion venting protective systems

MSZ EN 14797:2007 Explosion venting devices

¹MSZ EN 14994:2007 Gas explosion venting protective systems

¹MSZ EN 61508 Functional safety of electrical/electronic/programmable electronic safety-related systems

¹MSZ EN 61511-1 Functional safety. Safety instrumented systems for the process industry sector. Part 1: Framework, definitions, system, hardware and application programming requirements

¹MSZ EN ISO/IEC 80079-20-1:2020 Explosive atmospheres. Part 20-1: Material characteristics for gas and vapour classification. Test methods and data (ISO/IEC 80079-20-1:2017, including Amendment 1 of 2018)

¹MSZ EN ISO/IEC 80079-20-2:2016 Explosive atmospheres. Part 20-2: Material characteristics. Combustible dusts test methods (ISO/IEC 80079-20-2:2016)

¹MSZ EN ISO 80079-36:2016 Explosive atmospheres. Part 36: Non-electrical equipment for explosive atmospheres. Basic method and requirements (ISO 80079-36:2016)

¹MSZ EN ISO 80079-37:2016 Explosive atmospheres. Part 37: Non-electrical equipment for explosive atmospheres. Non-electrical type of protection constructional safety "c", control of ignition sources "b", liquid immersion "k" (ISO 80079-37:2016)

²Directive:

²CEN/TR 15281 Guidance on Inerting for the Prevention of Explosions

¹modified 15.01.2021.

²modified 13.06.2022

Annex A**1 Methodology of zoning with an example****A.1. 1 Zoning process for areas with potentially explosive atmospheres of combustible gases, vapour or mists:**

A.1.1. 1 Recording of the technological process (type and frequency of the activity and the materials used).

A.1.2. 1 Determination of the relevant physical parameters of potentially explosive substances:

- a) CAS number
- b) name
- c) flash point
- d) relative density
- e) LFL (m/m% and v/v%)
- f) gas group
- g) burning point
- h) temperature class
- i) other characteristics:
 - ia) in some cases, the density of liquid etc. (for liquids)
 - ib) polytropic index of adiabatic expansion etc. (for gases).

A.1.3. Selection of the standard to serve as a basis for zoning. The availability of sectoral standards (international or domestic) or technical regulatory documents (international or domestic) for the given technology with sections specifically dedicated to zoning and actual zones should be considered.

a) If such a standard or regulatory document is available, they shall be applied for the zoning process and referred in the zoning documents. The process should proceed from A.1.6.

b) If such a standard or regulatory document is not available, the process shall proceed from A.1.4.

Note:

Zoning calculations may also be performed in cases where other (technical and legal) documents are with sections specifically dedicated to zoning and actual zones.

A.1.4. Recording the input data for zoning calculations:

- a) name of source of release
- b) location of release (confined space, open area with limited ventilation, open area)
- c) height and direction of release
- d) wind speed or air current to be considered (ventilation)
- e) physical state before and after release
- f) release mechanics (pressure conditions, temperature conditions, cross sections, surfaces, etc.)

A.1.5. Calculations for releases and the extension of zones:

- a) grade of release (continuous, primary, secondary)
- b) operational safety of ventilation (good, adequate or poor)
- c) rate of release (g/s)

¹modified 15.01.2021.

²modified 13.06.2022

- d) release characteristics (m^3/s)
- e) geometry of space formed around the release
- f) degree of dilution (strong, medium or weak), determined from the calculations performed and the relations provided in the standard

A.1.6. At the end of the process, the following data should be recorded:

- a) the extension of the zone with potentially explosive atmosphere in every direction (simple solid figures should be used such as sphere, cylinder, cone or combinations thereof),
- b) type of zone,
- c) gas group,
- d) temperature class.

A.1.7. At the end of the process, the following shall be provided:

- a) plan and section drawings.
- b) legend for drawings.

A.2. ²Calculations for zoning according to MSZ EN IEC 60079-10-1. Determining the extension of zones with potentially explosive atmospheres

A.2.1. ²The input data for calculating the extension of zones with potentially explosive atmospheres are given by Table A.1 of MSZ EN IEC 60079-10-1 (hereinafter and for the purposes of Annex A: the Standard).

A.2.2. ²In the present example, the zoning process for the area with a potentially explosive atmosphere forming around a single flange with a flat seal for a pipe connection of a DN200 methane pipeline of MOP (Maximum Operating Pressure) = 64 bar, located at a height of 6 m in an open area a well ventilated in every direction:

¹ Recording input data:

name of hazardous substance	² methane
molar mass	16.04 g/mol
relative density (reference: air)	0.55
polytropic index of adiabatic expansion (γ)	to be calculated
flash point	does not apply to combustible gases
ignition temperature	600 °C
lower flammability limit (LFL)	4.4 v/v%
upper flammability limit (UFL)	17.0 v/v%
gas group	IIA
temperature class	T1
source of release	flange
location of source of release	open area
height of source of release	6 m

A.2.3. According to 3.4.4 of the Standard, the flange in question is a secondary grade source of release. Critical pressure according to B.7.2.3.1 of the Standard:

¹modified 15.01.2021.

²modified 13.06.2022

$$P_c = P_a \left(\frac{\gamma + 1}{2} \right)^{\frac{\gamma}{\gamma - 1}} [Pa]$$

A.2.4. For ideal gases:

$$\gamma = \frac{M * c_p}{M * c_p - R} \text{ [dimenzió nélküli szám]}$$

where

P_c	Kritikus nyomás:	számolandó	Pa
P_a	Atmoszférikus nyomás:	101 325	Pa
γ	Adiabaticus expanzió politrop indexe:	számolandó	-
c_p	a metán fajlagos hő állandó nyomáson:	2226	J kg ⁻¹ K ⁻¹ (300 K-en)
M	a metán móltömege:	16,04	kg/kmol
R	Egyetemes gázállandó:	8314	J kmol ⁻¹ K ⁻¹

critical pressure	to be calculated
atmospheric pressure	101 325
polytropic index of adiabatic expansion	to be calculated
specific heat of methane at constant pressure	2226
molar mass of methane	16.04
universal gas constant	8314

Accordingly:

$$\gamma = \frac{M * c_p}{M * c_p - R} = 1,30$$

$$P_c = P_a \left(\frac{\gamma + 1}{2} \right)^{\frac{\gamma}{\gamma - 1}} = 185\,887 \text{ Pa} = 1,86 \text{ bar} < 64 \text{ bar}$$

A.2.5. Based on the calculations, the internal pressure of the flange exceeds the critical pressure. In such cases, the rate of release is determined according to B.7.2.3.3 of the Standard:

$$W_g = C_d * S * p * \sqrt{\left(\frac{\gamma * M}{Z * R * T} \right) * \left(\frac{2}{\gamma + 1} \right)^{\frac{\gamma + 1}{\gamma - 1}}} \left[\frac{kg}{s} \right]$$

Flow rate of release:

$$Q_g = \frac{W_g}{\rho_g} \left[\frac{m^3}{s} \right]$$

¹modified 15.01.2021.

²modified 13.06.2022

Where:

W_g	Kibocsátás mértéke:	számolandó	kg s^{-1}
C_d	fúvóka koefficiens:	1	-
S	Annak a nyílásnak a keresztmetszete, amelyen keresztül a gáz eltávozik:	0,0000025 *	m^2
p	Nyomás	6 501 325	Pa
Z	komprimálási faktor:	1	-
T	hőmérséklet:	298	K
Q_g	Kibocsátás mértéke (tömegáram):	számolandó	$\text{m}^3 \text{s}^{-1}$
ρ_g	metán gáz sűrűsége atmoszférikus nyomáson:	0,6561	kg m^{-3}

* a nyílás keresztmetszetére a Szabvány B.1-es táblázata ad javaslatot

$$W_g = C_d * S * p * \sqrt{\left(\frac{\gamma * M}{Z * R * T}\right) * \left(\frac{2}{\gamma + 1}\right)^{\frac{\gamma+1}{\gamma-1}}} = 0,0276 \frac{\text{kg}}{\text{s}}$$

rate of release (to be calculated)
nozzle coefficient
diameter of the hole where the gas is released
pressure
compression factor
temperature
rate of release (to be calculated)
density of methane at atmospheric pressure

*recommended diameter values for the hole are given in Table B.1 of the Standard

Accordingly, the flow rate of release:

1 The flow rate of release:

$$Q_g = \frac{W_g}{\rho_g} = 0,042 \frac{\text{m}^3}{\text{s}}$$

A.2.6. According to Figure B.1 of the Standard, the form of the space section affected by the high-pressure jet-type release of gas (or vapour) depends on the nature of the gas (or vapour) release. Around a single flange in an open area, a spherical zone with potentially explosive atmosphere is formed according to section A.2 of the Standard.

A.2.7. 1 Calculating release characteristics according to Fig. C.1. of the Standard:

$$\text{Kibocsátási karakterisztika} = \frac{W_g}{\rho_g * k * A\acute{E}H} \left[\frac{\text{m}^3}{\text{s}} \right]$$

¹modified 15.01.2021.

²modified 13.06.2022

Where:

²The density of the gas is given in the previous table.

W_g	rate of release	to be calculated	kg s^{-1}
k	safety factor	1	-
LFL	lower flammability limit	4.4	$v/v\%$

Accordingly:

$$\text{Kibocsátási karakterisztika} = \frac{W_g}{\rho_g * k * A\acute{E}H} = 0,941 \frac{\text{m}^3}{\text{s}}$$

A.2.8. According to Table C.1 of the Standard, an air velocity of 2 m/s may be considered for natural ventilation, in the case of a source releasing a gas lighter than air and located higher than 5 m in an open area

A.2.9. The rate of dilution is given by Fig. C.1 of the Standard:

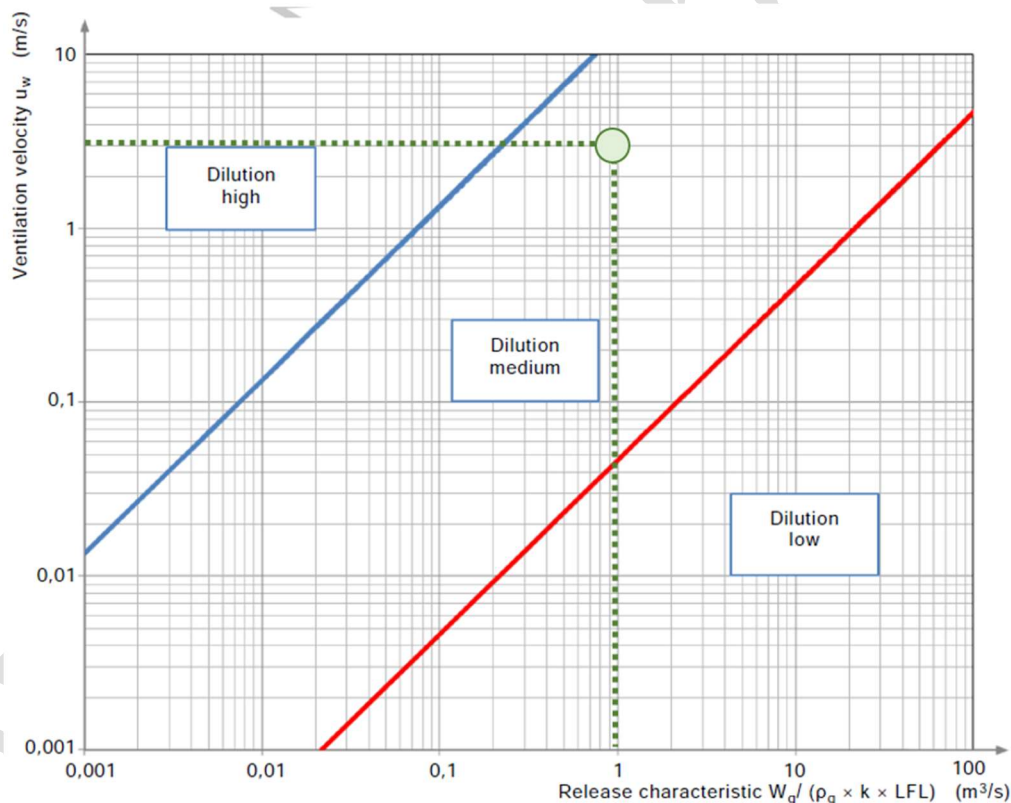

A.2.10. According to this graph, the rate of dilution provided by natural ventilation in the open area is „MEDIUM”.

A.2.11. The operational safety of natural ventilation in open areas is considered „GOOD”.

A.2.12. According to Table D.1 of the Standard, a Zone 2 area is formed, if:

- (a) the release source is rated as: SECONDARY GRADE
- (b) the rate of dilution is: MEDIUM
- (c) the operational safety of ventilation is: GOOD

¹modified 15.01.2021.

²modified 13.06.2022

A.2.13. Graph D.1 of the Standard determines the extension of the zones with potentially explosive atmospheres:

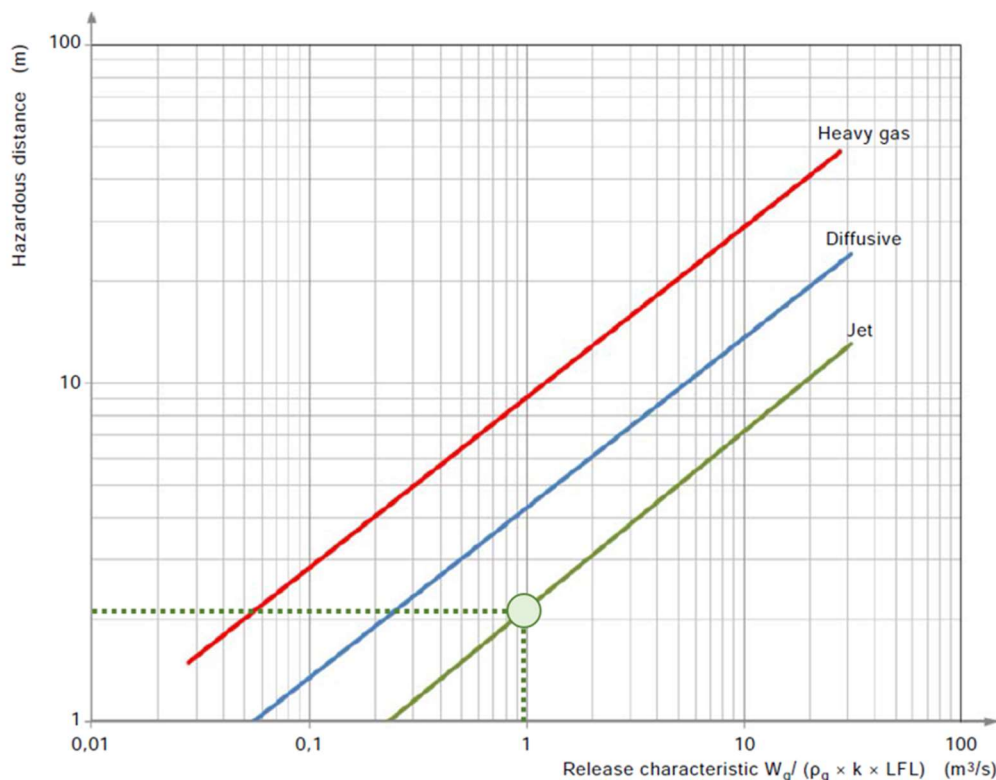

A.2.14. According to Fig. D.1 of the Standard, the release characteristic of 0.941m³/s corresponds to a distance of 2.1m. For the sake of increased safety and considering the true dimensions of the flange, the spherical area with a diameter of 2.5 m around the geometric midpoint of the flange shall be classified as: **Zone 2 IIA T1**

A.2.15. Zoning drawing:

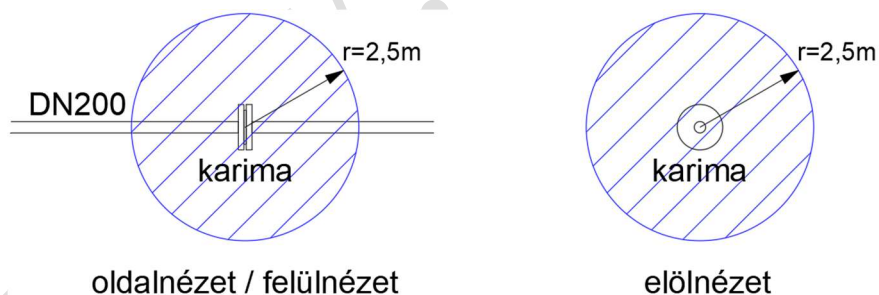

Jelmagyarázat

2-es zóna IIA T1

oldalnézet/felülnézet	side view/plan view
karima	flange
előlnézet	front view
jelmagyarázat	Legend
2-es zóna	Zone 2

¹modified 15.01.2021.

²modified 13.06.2022

1 Annex B
1 Determining the level of the risk of explosion

B.1. **1 Combustible liquids shall be considered to be of negligible risk of explosion in the following cases**

- B.1.1. **1** If, during the technological process concerned, the relevant indoor (Z) and outdoor (S) storage volumes and methods of use (M) remain below the values specified in the table, the risk of explosion is considered to be negligible.
- B.1.2. **1** In addition to the installation issues, fire and/or explosion hazards due to the technology, even of negligible, cannot be excluded. In such cases, fires and explosions shall be prevented by organisational measures regarding the performance of activities where necessary.
- B.1.3. **1** The total volume of combustible liquids in the table, as determined by the storage volumes and methods of use, shall be interpreted for a single room or single fire compartment defined by the storage area, for indoors and outdoors, respectively. Liquids may only be stored according to the manufacturer's instructions, (with the containers in a standing position).

	M-3	M-2	M-1
Z-1	100 l	20 l	2 l
Z-2	capacity of cabinets, but maximum 300 l/kg	capacity of cabinet, but maximum 300 l/kg	none

Methods of use (M)

M-3: passive storage

M-2: storage in containers resealed according to the manufacturer's instructions

M-1: manipulation or unloading within an hour

Storage volumes/usages indoors (Z)

Z-2: storage in fire proof cabinet (no other technical measures involved)

Z-1: storage in any other way

	M-3	M-2	M-1
S-1	1000 l	200 l	2 l
S-2	capacity of cabinet	none	none
S-3	capacity of container	none	none

Methods of use (M)

M-3: passive storage

M-2: storage in containers resealed according to the manufacturer's instructions

M-1: manipulation or unloading within an hour

Storage volumes/usages outdoors (S)

Z-3: storage in fire proof container (no other technical measures involved)

Z-2: storage in fire proof cabinet (no other technical measures involved)

¹modified 15.01.2021.

²modified 13.06.2022

Z-1: storage in any other way

B.2. 1,2 Aerosols containing combustible liquids or propellants shall be considered to be of negligible risk of explosion in the following cases:

B.2.1. 2 If, in the given process, an aerosol is used in a room with a ceiling height of at least 2.5 m and the volume used (sprayed) does not exceed 1 litre per hour, the sprayed volume shall be considered to be of negligible risk of explosion, taking into account the floor area of the room. The volume which can be safely used with regard to B2.2. may be calculated as a function of the floor area of the room, using the following formula:

$$V_{\text{sprayed aerosol}} = A_{\text{room}} \times k$$

where:

$V_{\text{sprayed aerosol}}$: maximum volume of the aerosol used within an hour

A_{room} : floor area of the room (m²)

$k=7.15$ safety factor (ml/ m²)

Examples:

- In a room with a floor area of 35 m², the maximum volume of aerosols that may be used each hour to keep risk of explosion negligible is 35 x 7.15 ≈ 250 ml (typically, 1 conventional can), provided that the rules of use are observed.

- In a room with a floor area of 140 m² or more, the maximum volume of aerosols that may be used each hour to keep risk of explosion negligible is 140 x 7.15 ≈ 1.000 ml (typically, 4 conventional cans), provided that the rules of use are observed.

B.2.1.1. 2 For aerosols with combustible propellants, the volume of aerosol stored shall not exceed 20 cans or 5 litres.

B.2.1.2. 2 For aerosols with non-combustible propellants, the volume of aerosol stored shall not exceed 80 cans or 20 litres.

B.2.1.3. 2 For pump aerosols without propellant and containing flammable liquid, the volume of aerosol stored shall not exceed 200 cans or 50 litres.

B.2.2. 1,2 During use and storage, aerosols shall be used in a ventilated area according to the manufacturer's instructions, in such a way that it does not result in fire or explosion hazards.

1,2 Note 1:

The volume of the explosive medium in these cases is below the standard value, so explosion hazard is not expected.

2 Note 2:

During use and storage, air exchange rate of at least twice an hour is assumed in the room.

B.3. 1 Intended uses and technologies shall be considered to be of negligible risk of explosion in the following cases:

B.3.1. 1 In the case of LPG or natural gas fired equipment and gas consuming technologies which are designed by authorised designers in compliance with the provisions of the relevant regulations, standards and technical-safety regulations by an authorized designer, constructed according to these designs, and the designer issues a written declaration on the negligible risk of explosion.

B.3.2. 1 The relevant legislation or standard specifically claims the intended use or technology not to pose a risk of explosion

B.3.3. 1 The domestic use of maximum one LPG cylinder of maximum 11.5 kg per residential home.

¹modified 15.01.2021.

²modified 13.06.2022

1 Annex C

1 Explosive dusts

C.1. Terms and definitions:

- a) *potentially explosive dust atmosphere*: a mixture of combustible dust, fibres or suspended solids with air where self-sustained combustion will spread by itself after ignition under normal atmospheric conditions.
- b) *potentially explosive dust*: an umbrella term for combustible dusts and combustible fibres.
- c) *combustible fibres*: solid particles with a nominal particle size exceeding 500 µm, including fibres that may be suspended in the air or settle from the atmosphere due their weight; they include suspended particles e.g. rayon, cotton (including cotton fluff and cotton waste).
- d) *combustible dust*: finely divided solid particles with a nominal particle size up to 500 µm that may be suspended in air or settle due to their weight; they may burn or smoulder in the air and form explosive mixtures with air at atmospheric pressure and normal temperature.
- e) *conductive dust*: combustible dusts with an electrical resistance not exceeding 1000 Ωm, e.g.: aluminium, titanium, zirconium.
- f) *non-conductive dust*: combustible dusts with an electrical resistance exceeding 1000 Ωm, e.g.: organic powders, sugar, cocoa powder, flour, sawdust.
- g) *layer ignition temperature*: the minimum temperature of a hot surface that can ignite a layer of dust of a pre-defined thickness on it.
- h) *minimum ignition temperature*: the lowest temperature of the interior wall of the explosion chamber at which the dust cloud in the chamber will ignite.
- i) *K value*: constant which gives the maximum instantaneous rate of explosion pressure rise (dp/dt_m) for an explosion in an explosion chamber with a volume 'V'.
- j) *K_{st} explosion coefficient*: the highest K value, to be determined by tests performed for a broad range of concentrations of the examined component. Explosion strength may be estimated from K_{st}.

Note:

Having sufficient information on the potentially explosive substance is essential for implementing suitable measures.

Dust explosion class	K _{st} [bar m/s]	Explosive property	Dust type
St 0	0	No explosion	Non-explosive dusts
St 1	0 < K _{st} < 200	Weak explosion	flour, sugar
St 2	200 ≤ K _{st} < 300	Strong explosion	organic dyes, sawdust
St 3	300 ≤ K _{st}	Very strong explosion	metal powders, e.g. aluminium

- k) *(dp/dt)_{max} maximum rate of explosion pressure rise*: the value of the rate of explosion pressure rise, calculated using the formula, which corresponds to K_{st} (the explosion coefficient) as measured in the explosion chamber of volume 'V'. Unit of measure: bar/s.
- l) *p_m explosion overpressure*: maximum explosion overpressure compared to the initial pressure, as measured in the explosion chamber. Unit of measure: bar.
- m) *p_{max} maximum explosion overpressure*: the maximum value of the explosion overpressure p_m, to be determined by tests in a broad range of concentrations of the examined component. Unit of measure: bar.
- n) *minimum ignition energy (MIE)*: the minimum ignition energy is one of the most important indicators, as its value gives the minimum energy at which the dust may be ignited. Unit of measure: Joule.

C.2. Areas and technologies with potentially explosive dust atmospheres

¹modified 15.01.2021.

²modified 13.06.2022

C.2.1. Dust explosion risk shall be assessed for all areas where combustible dusts are processed, produced, stored or transferred.

C.2.2. If a dust has explosive properties, the electrical and non-electrical products and the protection systems operating in the established zones with potentially explosive atmospheres shall be designed and operated in accordance with the principles set out in Chapters 3 and 4 of this TvMI.

C.3. Dust explosions

C.3.1. During a dust explosion, a chemical reaction with rapid heat release develops:

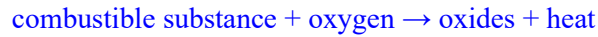

C.3.2. In special cases of dust explosion, metal powders may enter into exothermic reactions with nitrogen or carbon dioxide, but most often it is the oxygen in the air that facilitates oxidation.

C.3.3. Dust explosions often involve the following groups of substances:

- natural organic substances (cereals, wood, flax, sugar, etc.),
- synthetic organic substances (plastics, organic dyes, pesticides, medicines, etc.),
- coal and peat,
- metals (aluminium, magnesium, titanium, zinc, iron, etc.),

C.3.4. The dust clouds of substances that cannot be easily oxidized, such as silicates, sulphates, nitrates, carbonates and phosphates, sand, limestone, etc. – cannot support dust explosions.

C.3.5. Conditions supporting dust explosions:

C.3.5.1. For an explosion to occur, certain conditions must be fulfilled simultaneously:

- combustible substance,
- oxidizing agent,
- ignition source (with sufficient energy to ignite the dust cloud),
- suspended particles,
- particle size below 0.5 mm,
- dust concentration between the upper and the lower flammability limit,
- dust cloud in a confined or semi-confined space

C.3.6. **Determining explosive properties for dusts**

C.3.6.1. The explosive properties of dusts may be determined by laboratory tests or from the relevant references.

C.3.6.2. The process of the laboratory test is illustrated by Fig. C.1.

¹modified 15.01.2021.

²modified 13.06.2022

POR ROBBANÁSI TULAJDONSÁGAINAK
LABORATÓRIUMI MEGHATÁROZÁSA

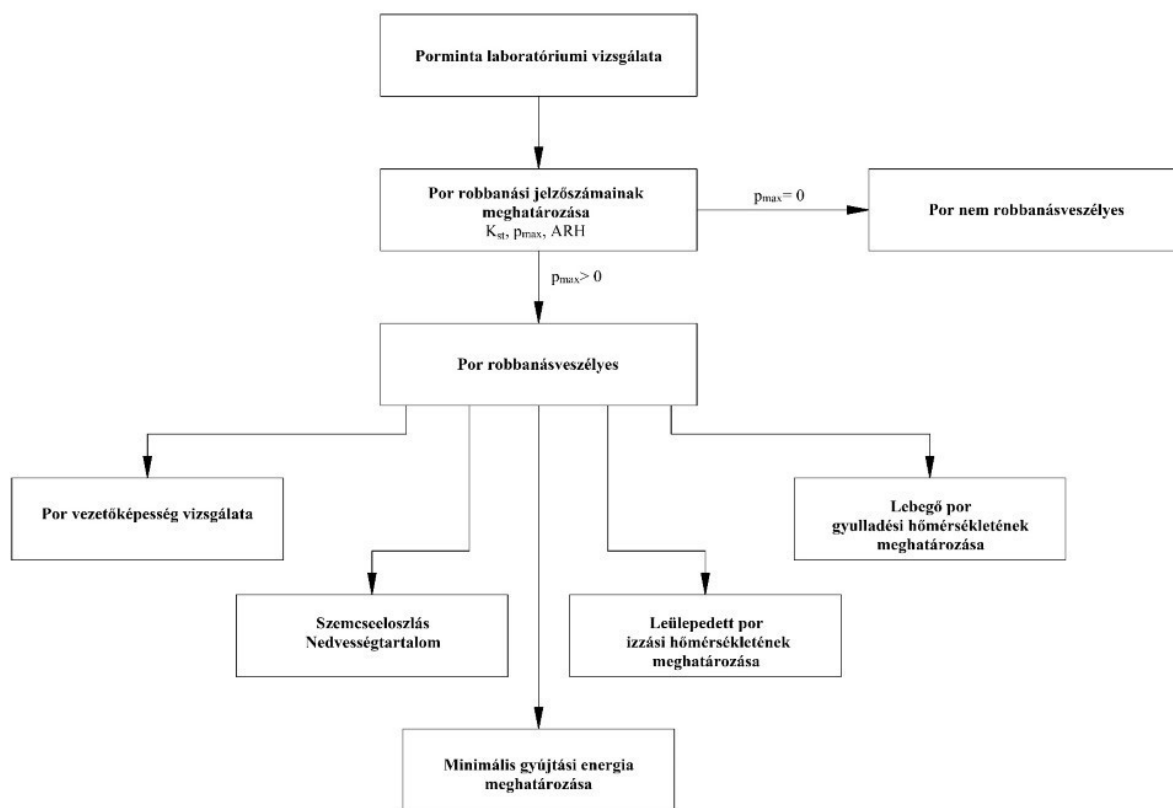

Por robbanási tulajdonságainak laboratóriumi vizsgálata	Laboratory testing of dust properties
Porminta laboratóriumi vizsgálata	Laboratory testing of dust sample
Por robbanási jelzőszámainak meghatározása	Determining the explosive properties of dust
Por robbanásveszélyes	Explosive dust
Por vezetőképesség vizsgálata	Conductivity test
Por nem robbanásveszélyes	Non-explosive dust
Szemcseeloszlás	Particle distribution
Nedvességtartalom	Moisture content
Minimális gyújtási energia meghatározása	Determining minimum ignition energy
Leülepedett por izzási hőmérsékletének meghatározása	Determining layer ignition temperature for settled dust
Lebegő por gyulladási hőmérsékletének meghatározása	Determining ignition temperature for suspended particles

Fig. C.1

C.3.7. Factors influencing dust explosions

C.3.7.1. Dust explosion risk depends on several factors. It is essentially a factor of physical and chemical properties of the dust, but it is also influenced by the environment and the space where the particles are suspended forming a dust cloud.

a) The most important factor is the dust itself.

In the case of a dust explosion, the dust itself may change (burn) and generate combustion products. The effects of an explosion may be measured by standardized tests. The two most important parameters are the maximum explosion pressure and the maximum rate of explosion pressure rise (detonation speed), also indicated by the explosion coefficient K_{st} .

b) Composition of dusts: some dusts (e.g. coal dust) are not homogeneous, so their explosive properties may be related to the distribution of particles.

c) Particle size and particle size distribution: finer particles have a higher specific surface area and thus pose a higher risk of explosion.

¹modified 15.01.2021.

²modified 13.06.2022

As the particle diameter decreases, the flash point gradually decreases, too. The finer the particles, the greater the dust explosion hazard. The intensity of dust explosion depends on the maximum explosion pressure (p_{\max}) in the confined space, the maximum rate of explosion pressure rise $(dp/dt)_{\max}$ and the explosion coefficient K_{st} . Regarding K_{st} , generally the higher its value, the more intense the dust explosion is, but it only applies only up to a certain particle size limit.

In addition to explosive properties, particle composition and the particle size of the main mass of the explosive dust shall also be considered.

- d) Dust concentration: The lower flammability limit (LFL) for dusts is usually between 10 and 100 g/m³. Over the upper flammability limit (UFL) the dust cloud cannot be ignited. Explosive concentrations are those between LFL and UFL.
- e) Moisture content with increasing moisture content, dust explosion hazard decreases and the flash point increases. The moisture normally absorbed by the dust from the air increases its flash point, so wetting should be considered as inerting.
- f) Ambient temperature and pressure: if the dust concentration in a given space increases, the ambient temperature will decrease. However, the increase of maximum explosion pressure will not be affected.
- g) Agitation of dust, turbulence: The larger the turbulence of the dust cloud, the more destructive the dust explosion will be.
- h) Combustible gas in the dust cloud (hybrid dust cloud).
- i) Layer thickness. The thickness of the settled dust layer may be reduced by cleaning at a sufficient frequency.

C.3.8. Explosion of hybrid dust clouds

C.3.8.1. A dust cloud that contains combustible gases, vapours, or liquids is called a hybrid dust cloud. Igniting a hybrid dust cloud takes much less energy than the ignition energy needed for a pure dust cloud. Dust clouds of coarse particles that cannot be ignited even with high-energy sparks or other heat sources turn into explosive hybrid clouds in the presence of the vapour solvents, at a concentration as low as 1-2%. The lower explosion limit of a hybrid dust cloud is also below that of a corresponding pure dust cloud.

C.3.8.2. If the combustible substance content of the hybrid dust cloud is less than 0.2 m/m%, it will behave as a pure dust cloud in the case of an explosion. Gases that generate low intensity explosions (e.g. methane) increase the explosion hazard related to the hybrid cloud much more than gases or vapours giving rise to high intensity explosion (e.g. hydrogen), because a rapid gas explosion ends before the explosion of the dust cloud even begins.

C.3.9. Primary and secondary dust explosions

C.3.9.1. Dust explosions may take place in two phases.

C.3.9.1.1. Dust explosions in closed systems that may be traced back to an ignition source are called *primary explosions*.

The primary dust explosion agitates the previously settled dust at the explosion site, which then transforms into a dust cloud of explosive concentration. This dust cloud fills the atmosphere completely or partially.

C.3.9.1.2. Smouldering dust particles and other combustion residues from the primary explosion serve as the ignition sources of the agitated dust cloud, thus a *secondary explosion* is generated.

Settled dust takes up very little space (a layer of dust of 1mm may have a concentration of 500 kg/m³), but when agitated, the concentration of a 5 m tall dust cloud may reach 100g/m³.

Note:

The consequences of a secondary dust explosion, due to the domino effect, may be catastrophic. Dust explosions may occur not only where the dust is generated, but also at the end users.

¹modified 15.01.2021.

²modified 13.06.2022

C.4. Areas with explosive dusts. Defining zones with potentially explosive atmospheres.

C.4.1. The definition of the zones with potentially explosive dust atmospheres is given by MSZ EN 60079-10-2.

C.4.2. The classification of zones created by explosive dusts depends on the frequency and duration of release of the explosive dust.

C.4.3. Settled dust layers are also considered sources of potentially explosive atmospheres. The area with potentially explosive atmospheres extends from the source or point of release until the parts where the conditions for dust explosion are not met any more. In closed or semi-closed systems, explosive dust carried away by air currents may settle at a distance from the source of release; this shall be considered when calculating the extension of the zones with potentially explosive dust atmospheres.

C.4.4. Zone with potentially explosive atmospheres:

a) **Zone 20:**

a place in which an explosive atmosphere, in the form of a cloud of combustible dust mixed with air, is present continuously, or frequently for long periods. The explosive mixture is present continuously (over 1000 h/year) and in high quantities.

Zone 20 areas typically include the interior of pipelines, silos, bunkers and production equipment as well as the technologies where the transfer of powders results in the formation of a continuous cloud of falling dust.

Zone 20 areas may include:

- interior of dust containers,
- interior of silos, cyclones and filters,
- powder conveyors and chain conveyors,
- interior of mixing equipment, mills, dryers, bag filling equipment.

b) **Zone 21:**

A place in which an explosive atmosphere, in the form of a cloud of combustible dust mixed with air is likely to occur in normal operation occasionally. The duration of the presence of the explosive mixture is between 10 and 1000 h/year.

The extent of the area with potentially explosive atmosphere depends on the flow rate of the dust, its particle size and its moisture content. The sources of release shall be assessed. In well ventilated open areas, weather conditions (wind, precipitation) shall be considered.

Zone 21 areas may include:

- external areas of closed systems (loading and unloading equipment),
- the external surfaces of dust containers and the immediate vicinity of their openings which are frequently used and where suspended particles of explosive dusts are frequently present,
- loading and unloading points, sampling points where the applied technology does not generate explosive atmospheres,
- external surfaces of dust containers where dust may settle during operation and the settled layer is likely to be stirred up and release suspended particles,
- the interior of dust containers, which are only occasionally filled or emptied and does not contain explosive atmospheres either continuously or often.

The zone forming around the source of release with a particular radius shall have a boundary in the vertical direction formed by the ground or the surface of some other, near horizontal solid structure (e.g. a solid platform or a roof). Where the spreading of the dust cloud is limited by mechanical structures, these should be considered as zone boundaries.

In most cases, the areas around Zone 21 ones should be classified as Zone 22. Where the boundaries of a Zone 21 area are characterised by settled dust, the extension of the zone may be increased or this part should be classified as Zone 22.

c) **Zone 22:**

¹modified 15.01.2021.

²modified 13.06.2022

A place in which an explosive atmosphere in the form of a cloud of combustible dust mixed with air is not likely to occur in normal operation but, if it does occur, will persist for a short period only.

The extent of the area with potentially explosive atmosphere caused by secondary grade releases depends on the amount of dust released, particle size, the moisture content of the dust and its flow rate. These parameters shall be considered together when determining the dimensions of the zone.

The zone forming around the source of release with a particular radius shall reach the ground in the vertical direction.

In well ventilated open areas, weather conditions (wind, precipitation) shall be considered.

Zone 22 areas may include:

- outlet points of bag filters, where malfunctions may result in the formation of a potentially explosive atmospheres,
- the immediate surroundings of the openings of containers which are seldom used or seldom opened and which, when opened, may contain suspended particles of explosive dusts,
- storage rooms for bags containing dust (e.g. flour bags),
- areas immediately adjacent to Zone 21 spaces with good ventilation, such as the immediate vicinity of loading and unloading points or sampling points,
- areas where the thickness of settled dust layers cannot be controlled and at the same time external factors may result in hazard.

Note 1:

If the settled dust is removed before it becomes hazardous, the area may be classified as non-hazardous.

Note 2:

The relevant properties for all dusts present at a particular technological site shall be supported by safety data sheets or accredited laboratory measurements, otherwise the zoning process cannot be performed.

C.5. Explosion groups for dusts

C.5.1. The explosion groups of solid explosive substances are defined in MSZ EN IEC 60079-0: 2018.

Explosion group	Type of substance	Note	
IIIA	Combustible fibres		e.g.: duck feather, goose feather, textile fibres, flock fibres, etc.
IIIB	Non-conductive dusts	<u>Non-conductive dusts:</u> their specific electrical resistance exceeds 1000 Ωm	e.g.: maize starch, milk powder, flour, wheat, rapeseed powder, soy powder, sunflower powder, cellulose, pulp, organic powders, etc.
IIIC	Conductive dusts	<u>Conductive dusts:</u> their specific electrical resistance does not exceed 1000 Ωm	e.g.: aluminium powder, lithium, magnesium, tantalum, steel powder, bronze dust,

¹modified 15.01.2021.

²modified 13.06.2022

			titanium, zirconium, zinc, graphite, coal
--	--	--	--

C.6. Determining the allowed maximum surface temperature

C.6.1. For zoning, the allowed maximum surface temperature, ignition temperature and ignition temperature for dust layers shall be provided.

C.6.2. The allowed maximum surface temperature of products operating in potentially explosive atmospheres is determined as follows:

C.6.2.1. The surface temperature of products may not exceed 2/3 of the ignition temperature of the explosive dust present:

$$T_{max} = \frac{2}{3} T_{ign}$$

C.6.2.2. The surface temperature of products may not exceed the layer ignition temperature of the explosive dust present minus 75 K:

$$T_{max} = T_{ign,layer} - 75K \text{ (5-mm thick dust layer)}$$

C.6.2.3. Both T_{max} values shall be determined and the lowest of the two shall be applied as the allowed maximum surface temperature for the product.

Note:

If the allowed maximum surface temperature calculated for a given the zone with a potentially explosive dust atmosphere is so low that no compliant explosion-proof product is available, the product with the lowest achievable surface temperature shall be included in the design.

C.7. Formulas to calculate the allowed maximum surface temperature of products in the presence of gases/vapours and dusts

C.7.1. In the presence of gases and vapours, the temperature classes T1-T6 shall be provided for zoning. In the case of dusts, the allowed maximum surface temperature may only be defined after laboratory tests.

		T1	T2	T3	T4	T5	T6
EXPLOSION SAFETY MAJOR GROUP	GASES/VAPOURS	Ignition temperature of gases					
		$> 450^{\circ}C$	$300 - 450^{\circ}C$	$200 - 300^{\circ}C$	$135 - 200^{\circ}C$	$100 - 135^{\circ}C$	$85 - 135^{\circ}C$
		IIA	IIB	IIC			
	Maximum surface temperature of product						
		$450^{\circ}C$	$300^{\circ}C$	$200^{\circ}C$	$135^{\circ}C$	$100^{\circ}C$	$85^{\circ}C$
	DUSTS	According to Method A: $T_{max} = \frac{2}{3} T_{ign} / T_{max} = T_{ign \text{ 5mm layer}} - 75K \text{ (5 mm)}$ (From the two T_{max} the lower one shall be used.)					
		IIIA					
		IIIB					

¹modified 15.01.2021.

²modified 13.06.2022

		IIC	<p><i>According to Method B:</i></p> $T_{12,5max} = T_{12,5\text{ mm izzás}} - 25\text{ K (12,5 mm)}$
--	--	------------	---

C.8. Temperature limits due to the presence of dust layers

C.8.1. Where the thickness of the dust layer is not specified on the product in relation to the nominal temperature, the following safety factor may be applied, taking into account the thickness of the dust layer:

a) *Up to a layer thickness of 5 mm:*

The maximum surface temperature of the product – measured with the dust free test described by MSZ EN 60079-0 – may not exceed the value 75°C below the dust’s minimum ignition temperature established for a layer thickness of 5 mm of the particular dust:

$$T_{max} \leq T_{5mm} - 75^{\circ}C$$

where T_{5mm} is the minimum ignition temperature established for a dust layer thickness of 5 mm.

b) *Layer thickness between 5 and 50 mm:*

If there is a chance that a dust layer thicker than 5 mm may form on the product, the maximum surface temperature shall be reduced. Fig. C.2. provides guidelines for reducing the maximum surface temperature of products as a function of layer thickness where dusts with a minimum ignition temperature above 250 °C may form at least 5 mm thick layers.

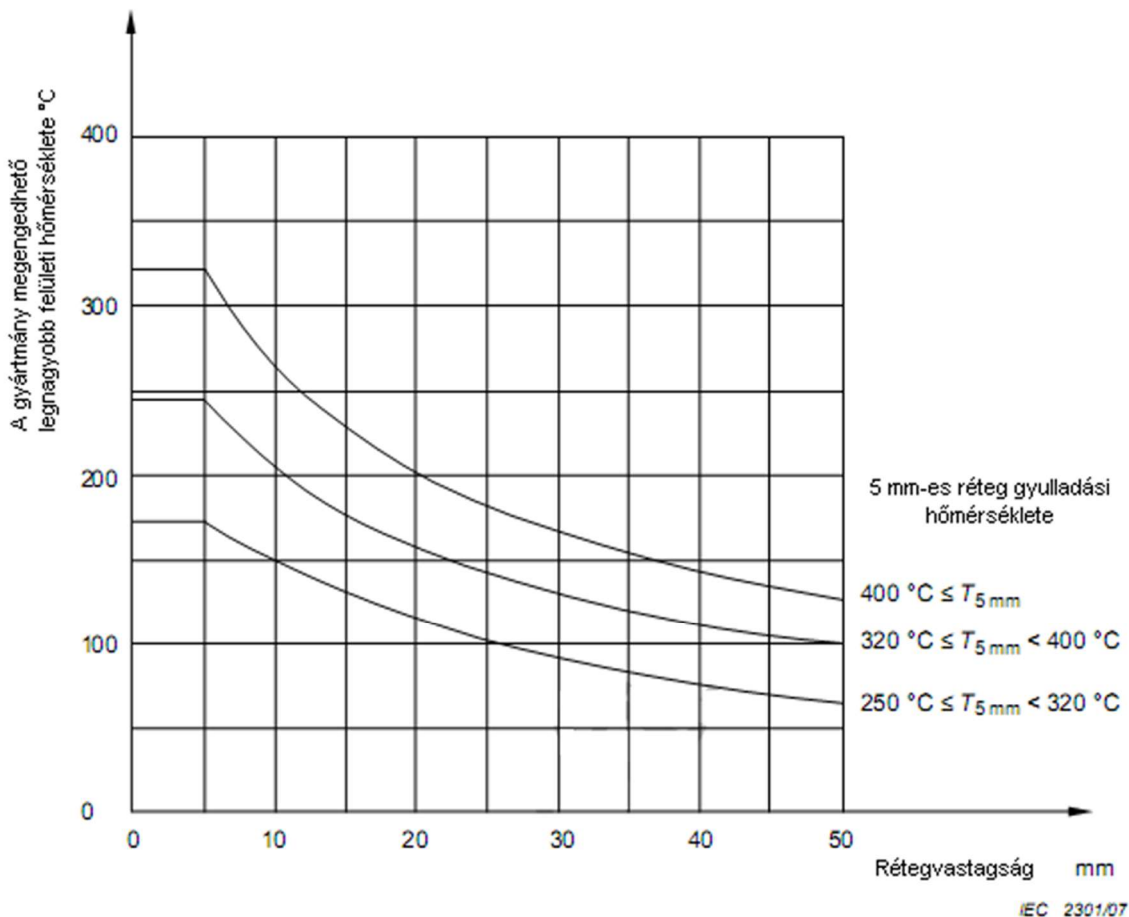

A gyártmány megengedhető legnagyobb felületi hőmérséklete	Maximum allowable surface temperature of product
5 mm-es réteg gyulladási hőmérséklete	Ignition temperature for 5-mm layer
Rétegvastagság	Layer thickness

Fig. C.2

¹modified 15.01.2021.

²modified 13.06.2022

Products with an ignition temperature below 250 °C for 5-mm thick dust layers shall be tested in a laboratory, if there is any doubt about the applicability of the graph.

c) *Dust layers of a thickness exceeding 50 mm (Unavoidable layers)*

If the formation of dust layers cannot be avoided around the sides and base of a product, or when the product is completely immersed in dust, reducing surface temperatures to much lower values may be justified, due to the thermal insulation effect of the dust. If a "Da" protection level is required in such a situation, all the requirements for EPL "Da" shall be met.

In cases where the thickness of the dust layer exceeds 50 mm, the maximum surface temperature of the product may be indicated as the maximum surface temperature TL, which in fact indicates the allowed thickness of the layer. If the product is marked as TL for a particular thickness, the ignition temperature of the combustible dust shall be used instead of T5mm, by a layer thickness L. The maximum TL surface temperature of the product shall be at least 75 °C lower than the ignition temperature of the combustible dust with a layer thickness L.

Note:

Where the dust related to the technology does not involve fibres, metal powders, graphite or coal, the dust group of the technology shall be IIIB.

C.9. Dust layers of excessive thickness

C.9.1. Examples of dust layers of excessive thickness are given by Fig. C.3.

	<p>Dust layer of excessive thickness on the top of the product</p>
	<p>Dust layer of excessive thickness on the top of the product, caused by low ignition temperature</p>
	<p>Dust layer of excessive thickness on the sides of the product</p>
	<p>Product fully covered by dust Dimensions <i>b</i>, <i>s</i> and <i>t</i> shall be restricted as justified by the laboratory tests.</p>

Fig. C.3

C.10. Marking of zones with potentially explosive dust atmospheres

C.10.1. An example of marking zones with potentially explosive dust atmospheres after the explosive parameters, conductivity, minimum ignition temperature for suspended particles and layer ignition temperature for settled dust have been determined by laboratory testing:

Zone 21IIIB T123°C

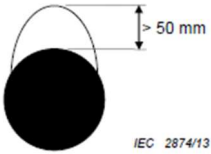
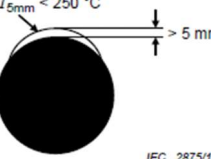
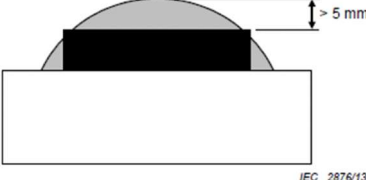
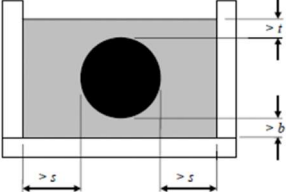
C.11. Selecting dust testing methods

¹modified 15.01.2021.

²modified 13.06.2022

- C.11.1. Gases, vapours, mists, dusts, and hybrid mixtures thereof may be characterised by their flammability and explosiveness. In practice, the safe handling of combustible materials used or generated during processing requires information of their hazardous properties.
- C.11.2. The *combustion and explosion tests* of substances involved in technologies provide the necessary information. *The combustion* (flammability) *tests* to be performed are defined by the potential ignition sources present in the technology.

Note:
 Test methods are provided by MSZ EN ISO/IEC 80079-20-2.

- C.11.3. The complete test of dusts include the testing of the following parameters:
 - (a) minimum ignition temperature (MIT) for suspended particles
 - b) layer ignition temperature (LIT) for settled dust,
 - (c) auto-ignition temperature (AIT).
- C.11.4. *Explosiveness* includes the following parameters (for normal state):
 - a) minimum ignition temperature (MIE),
 - b) maximum explosion overpressure (p_{max}),
 - c) maximum pressure increase rate ($[dp/dt]_{max}$),
 - d) explosion coefficient (K_{st}),
 - e) lower explosion limit (LEL),
 - f) upper explosion limit (UEL),
 - g) limiting oxygen concentration for inerting with nitrogen/carbon-dioxide (LOC) and
 - h) conductivity.

From these, the upper explosion limit and the inerting-dependent limiting oxygen concentration should only be determined in certain specific cases.

C.12. Minimum ignition energy (MIE)

C.12.1. In the case of explosive substances, minimum ignition energy is one of the most important explosive properties, as its value determines the lowest energy that may ignite the dust and cause an explosion.

Note:
 Test methods are provided by MSZ EN ISO/IEC 80079-20-2.

C.12.2. Dusts are classified into spark sensitivity classes according to their ignition energy values.

MINIMUM IGNITION ENERGY [MJ]	IGNITION SENSITIVITY CLASS
below 0.1	extremely high sensitivity
0.1- 4.0	high sensitivity
4.0 - 20.0	average sensitivity
over 20.0	low sensitivity

C.12.3. Explosive powders are classified into three categories according to their sensitivity (Fig. C.4)

- a) Dusts with $MIE_{1mH} < 10$ mJ are classified as having average sensitivity
- b) Dusts with $MIE_{0mH} < 10$ mJ are classified as sensitive
- c) Dusts with $MIE_{0mH} < 3$ mJ are classified as extremely sensitive

C.12.4. Where the only feasible preventive measure is to avoid the presence of efficient ignition sources, all relevant efficient ignition sources shall be eliminated

C.12.4.1. The more complex a technology is, the more difficult it is to reliably eliminate all efficient ignition sources.

¹modified 15.01.2021.
²modified 13.06.2022

C.12.4.2. Where explosive dusts with an ignition energy below 10 mJ are processed, extra protection measures shall be taken in addition to the elimination of efficient ignition sources. It should also be considered that the minimum ignition energy of explosive dusts decreases with increasing temperature.

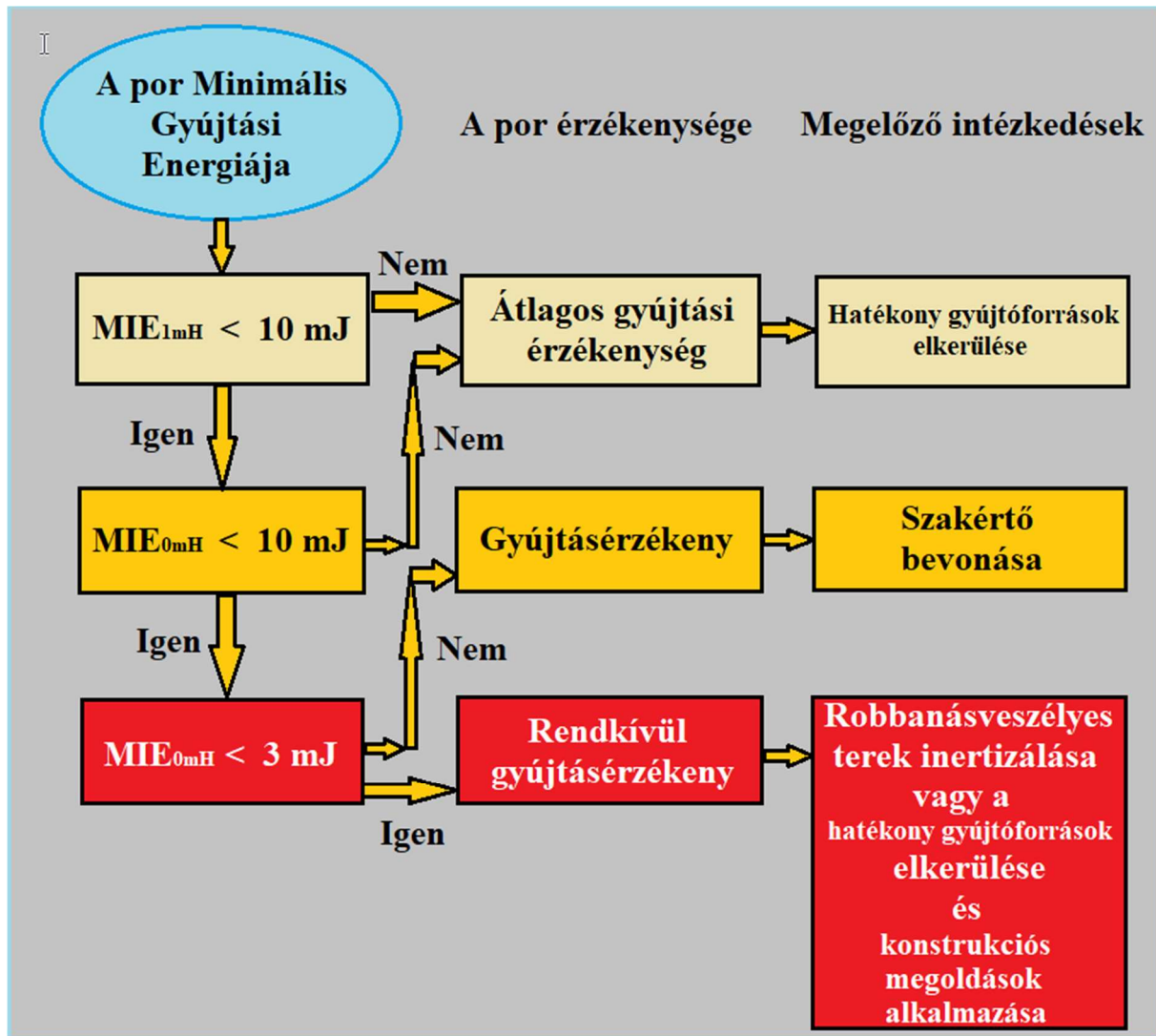

A por minimális gyújtási energiája	Minimum ignition energy of dust
A por érzékenysége	Dust sensitivity
Megelőző intézkedések	Preventive measures
Átlagos gyújtási érzékenység	Average sensitivity
Gyújtásérzékeny	Sensitivity to ignition
Rendkívül gyújtásérzékeny	Extremely high ignition sensitivity
Hatékony gyújtóforrások elkerülése	Eliminate efficient ignition sources
Szakértő bevonása	Involve expert
Robbanásveszélyes területek inertizálása vagy a hatékony gyújtóforrások elkerülése és konstrukciós megoldások alkalmazása	Inert areas with potentially explosive atmospheres or eliminate efficient ignition sources and use construction solutions

Fig C.4

C.12.5. In the case of dusts with *extremely high ignition sensitivity*, confined spaces may be inerted as an additional mode of protection. Due to the decrease in oxygen concentration, the ignition sensitivity of the explosive dust-air mixture decreases.

C.12.5.1. After the LOC test (limiting oxygen concentration for an inerted atmosphere), the oxygen concentration by which the dust cannot explode in the case of interting may be determined. The limiting oxygen concentration corresponds to the oxygen content where the maximum explosion overpressure (p_{max}) and the maximum pressure increase rate (dp/dt) are both exactly zero.

¹modified 15.01.2021.

²modified 13.06.2022

C.13. Cleaning plan

MSZ EN 60079-10-2 prescribes the preparation and application of a cleaning plan for spaces with potentially explosive dust atmospheres.

C.14. Modes of protection for spaces with potentially explosive dusts

Mode of protection	Relevant standard	Zone	Note
i _a	MSZ EN 60079-11	20/21/22	intrinsically safe
i _b	MSZ EN 60079-11	21/22	intrinsically safe
i _c	MSZ EN 60079-11	22	intrinsically safe
t _a / t _b / t _c	MSZ EN 60079-31	20/21/22	protection by enclosure and temperature limitation
p _x / p _y / p _z	MSZ EN 60079-2	21/22	protection by pressurized enclosure
m _a / m _b / m _c	MSZ EN 60079-18	20/21/22	protection by encapsulation within a compound ("m")
h	MSZ ISO 80079-37	20/21/22	mechanical protection

¹modified 15.01.2021.

²modified 13.06.2022